



---

# FREESTANDING OUTDOOR GRILL

## Installation Instructions and Use & Care Guide

For questions about features, operation/performance, parts, accessories or service, call: **1-877-373-2301**  
or visit our website at [www.Kitchenaidgrills.com](http://www.Kitchenaidgrills.com)

---

# ASADOR AUTÓNOMO PARA EXTERIOR

## Instrucciones de instalación y Manual de uso y cuidado

Para consultas respecto a características, funcionamiento, rendimiento, piezas, accesorios o servicio técnico, llame al: **1-877-373-2301**  
o visite nuestro sitio de internet en [www.Kitchenaidgrills.com](http://www.Kitchenaidgrills.com)

---

# COMPTOIR POUR GRIL D'EXTÉRIEUR AUTOPORTANT

## Instructions d'installation et Guide d'utilisation et d'entretien

Pour des questions à propos des caractéristiques, du fonctionnement/rendement, des pièces, des accessoires ou du service,  
composer le : **1-877-373-2301**  
ou visitez notre site web [www.Kitchenaidgrills.com](http://www.Kitchenaidgrills.com)

---

Table of Contents/Índice/Table des matières..... 2



## TABLE OF CONTENTS

<b>OUTDOOR GRILL SAFETY</b> .....	<b>3</b>	<b>OUTDOOR GRILL USE</b> .....	<b>25</b>
<b>INSTALLATION REQUIREMENTS</b> .....	<b>5</b>	Using Your Outdoor Grill .....	25
Tools and Parts .....	5	Hood Lights .....	26
Location Requirements .....	5	Using Your Searing Side Burner .....	27
Product Dimensions .....	6	Using Your Rotisserie Burner .....	28
Electrical Requirements .....	6	Rotisserie Cooking Tips .....	28
Gas Supply Requirements .....	7	<b>TIPS FOR OUTDOOR GRILLING</b> .....	<b>29</b>
Gas Connection Requirements.....	7	Cooking Methods.....	30
<b>REPLACEMENT PARTS</b> .....	<b>9</b>	Grilling Chart.....	30
All Pre-Assembled Screws List.....	12	<b>OUTDOOR GRILL CARE</b> .....	<b>32</b>
Package Content List.....	13	Replacing the Igniter Battery.....	32
<b>INSTALLATION INSTRUCTIONS</b> .....	<b>14</b>	Changing the Light Bulb.....	32
Freestanding Outdoor Grill Installation .....	14	General Cleaning .....	33
Make Gas Connection .....	17	<b>TROUBLESHOOTING</b> .....	<b>35</b>
<b>GAS CONVERSIONS</b> .....	<b>20</b>	<b>ASSISTANCE</b> .....	<b>35</b>
Tools and Parts for Gas Conversion.....	20	Accessories .....	35
Conversion from LP Gas to Natural Gas .....	20	<b>WARRANTY</b> .....	<b>36</b>
Check and Adjust the Burners .....	24		

## ÍNDICE

<b>SEGURIDAD DEL ASADOR PARA EXTERIORES</b> .....	<b>39</b>	<b>USO DEL ASADOR PARA EXTERIORES</b> .....	<b>61</b>
<b>REQUISITOS DE INSTALACIÓN</b> .....	<b>41</b>	Cómo usar el asador para exteriores.....	61
Herramientas y piezas.....	41	Luces de la capota .....	63
Requisitos de ubicación.....	41	Cómo usar el quemador lateral para dorado rápido .....	63
Medidas del producto .....	42	Cómo usar el quemador del rostizador .....	64
Requisitos eléctricos .....	42	Consejos para la cocción con el rostizador.....	65
Requisitos del suministro de gas .....	43	<b>CONSEJOS PARA ASAR AL AIRE LIBRE</b> .....	<b>66</b>
Requisitos para la conexión de gas.....	44	Métodos de cocción .....	66
All Pre-Assembled Screws List.....	48	Cuadro para asar.....	67
Paquete Lista De Contenido.....	49	<b>CUIDADO DEL ASADOR PARA EXTERIORES</b> .....	<b>69</b>
<b>INSTRUCCIONES DE INSTALACIÓN</b> .....	<b>50</b>	Cómo reemplazar la batería del encendedor .....	69
Instalación del asador autónomo para exteriores .....	50	Cómo cambiar el foco.....	69
Conexión del suministro de gas .....	54	Limpieza general .....	70
<b>CONVERSIONES DE GAS</b> .....	<b>56</b>	<b>SOLUCIÓN DE PROBLEMAS</b> .....	<b>72</b>
Herramientas y piezas para la		<b>ASISTENCIA</b> .....	<b>73</b>
conversión de gas.....	56	Accesorios .....	73
Conversión de gas LP a gas natural .....	56	<b>GARANTÍA</b> .....	<b>73</b>
Revise y regule los quemadores.....	59		

## TABLE DES MATIÈRES

<b>SÉCURITÉ DU GRIL D'EXTÉRIEUR</b> .....	<b>76</b>	<b>UTILISATION DU GRIL D'EXTÉRIEUR</b> .....	<b>97</b>
<b>EXIGENCES D'INSTALLATION</b> .....	<b>78</b>	Utilisation du gril d'extérieur.....	98
Outils et pièces.....	78	Lampes sous le couvercle.....	99
Exigences d'emplacement.....	78	Utilisation du brûleur à rôtissage latéral.....	99
Dimensions du produit.....	79	Utilisation du brûleur de tournebroche .....	101
Spécifications électriques .....	79	Conseils de cuisson à l'aide du tournebroche .....	101
Spécifications de l'alimentation en gaz .....	80	<b>CONSEILS POUR L'UTILISATION DU GRIL D'EXTÉRIEUR</b> ..	<b>103</b>
Exigences concernant le raccordement au gaz .....	81	Méthodes de cuisson .....	103
<b>PIÈCES DE RECHANGE</b> .....	<b>82</b>	Tableau de cuisson au gril .....	104
All Pre-Assembled Screws List.....	85	<b>ENTRETIEN DU GRIL D'EXTÉRIEUR</b> .....	<b>107</b>
Package Content List.....	86	Remplacement de la pile de l'allumeur.....	107
<b>INSTRUCTIONS D'INSTALLATION</b> .....	<b>87</b>	Changement de l'ampoule d'éclairage .....	107
Installation du gril d'extérieur autoportant.....	87	Nettoyage général .....	108
Raccordement au gaz.....	90	<b>DÉPANNAGE</b> .....	<b>110</b>
<b>CONVERSIONS POUR CHANGEMENT DE GAZ</b> .....	<b>92</b>	<b>ASSISTANCE</b> .....	<b>110</b>
Outils et pièces pour conversion de gaz .....	92	Accessoires .....	110
Conversion de propane à gaz naturel.....	93	<b>GARANTIE</b> .....	<b>111</b>
Contrôle et réglage des brûleurs .....	96		

# OUTDOOR GRILL SAFETY

## Your safety and the safety of others are very important.

We have provided many important safety messages in this manual and on your appliance. Always read and obey all safety messages.



This is the safety alert symbol.

This symbol alerts you to potential hazards that can kill or hurt you and others.

All safety messages will follow the safety alert symbol and either the word “DANGER” or “WARNING.”

These words mean:

**⚠ DANGER**

You can be killed or seriously injured if you don't immediately follow instructions.

**⚠ WARNING**

You can be killed or seriously injured if you don't follow instructions.

All safety messages will tell you what the potential hazard is, tell you how to reduce the chance of injury, and tell you what can happen if the instructions are not followed.

### **⚠ DANGER**

If you smell gas:

1. Shut off gas to the appliance.
2. Extinguish any open flame.
3. Open lid.
4. If odor continues, keep away from the appliance and immediately call your gas supplier or your fire department.

### **⚠ WARNING**

1. Do not store or use gasoline or other flammable liquids or vapors in the vicinity of this or any other appliance.
2. An LP cylinder not connected for use shall not be stored in the vicinity of this or any other appliance.

State of California Proposition 65 Warnings:

WARNING: This product contains one or more chemicals known to the State of California to cause cancer.

WARNING: This product contains one or more chemicals known to the State of California to cause birth defects or other reproductive harm.

In the State of Massachusetts, the following installation instructions apply:

- Installations and repairs must be performed by a qualified or licensed contractor, plumber, or gasfitter qualified or licensed by the State of Massachusetts.
- If using a ball valve, it shall be a T-handle type.
- A flexible gas connector, when used, must not exceed 3 feet.

**IMPORTANT:** This grill is manufactured for outdoor use only. For grills that are to be used at elevations above 2000 ft (609.6 m) orifice conversion is required. See “Gas Supply Requirements” section. It is the responsibility of the installer to comply with the minimum installation clearances specified on the model/serial rating plate. The model/serial rating plate for freestanding models can be found inside left-hand cabinet door.

# IMPORTANT SAFETY INSTRUCTIONS

**WARNING:** To reduce the risk of fire, electrical shock, injury to persons, or damage when using the outdoor cooking gas appliance, follow basic precautions, including the following:

- Do not install portable or built-in outdoor cooking gas appliances in or on a recreational vehicle, portable trailer, boat or in any other moving installation.
- Always maintain minimum clearances from combustible construction, see "Location Requirements" section.
- The outdoor cooking gas appliance shall not be located under overhead unprotected combustible construction.
- This outdoor cooking gas appliance shall be used only outdoors and shall not be used in a building, garage, or any other enclosed area.
- Keep any electrical supply cord and fuel supply hose away from any heated surfaces.
- Keep outdoor cooking gas appliance area clear and free from combustible materials, gasoline and other flammable vapors and liquids.
- Do not obstruct the flow of combustion and ventilation air. Keep the ventilation openings of the cylinder enclosure free and clear from debris.
- Open the cabinet door and inspect the gas cylinder supply hose before each use of the outdoor cooking gas appliance. If the hose shows excessive abrasion or wear, or is cut, it **MUST** be replaced before using the outdoor cooking gas appliance. Contact your dealer and use only replacement hoses specified for use with the outdoor cooking gas appliance.
- Visually check the burner flames. They should be blue. Slight yellow tipping is normal for LP gas. The flames should be approximately 1" (2.5 cm) high.
- Check and clean burner/venturi tube for insects and insect nest. A clogged tube can lead to fire under the outdoor cooking gas appliance.

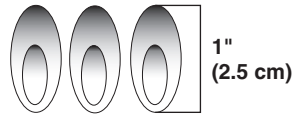

- The LP gas supply cylinder to be used must be:
    - constructed and marked in accordance with the Specification for LP Gas Cylinders of the U.S. Department of Transportation (DOT) or the National Standard of Canada, CAN/CSA-B339, Cylinders, Spheres, and Tubes for Transportation of Dangerous Goods; and Commission.
    - provided with a listed overfilling prevention device.
    - provided with a cylinder connection device compatible with the connection for outdoor cooking gas appliances.
  - Always check connections for leaks each time you connect and disconnect the LP gas supply cylinder. See "Installation Instructions" section.
  - When the outdoor cooking gas appliance is not in use, the gas must be turned off at the supply cylinder.
  - Storage of an outdoor cooking gas appliance indoors is permissible only if the cylinder is disconnected and removed from the outdoor cooking gas appliance.
  - Cylinders must be stored outdoors and out of the reach of children and must not be stored in a building, garage, or any other enclosed area.
  - The pressure regulator and hose assembly supplied with the outdoor cooking gas appliance must be used. A replacement pressure regulator and hose assembly specific to your model is available from your outdoor cooking gas appliance dealer.
  - Gas cylinder must include a collar to protect the cylinder valve.
  - For appliances designed to use a CGA791 Connection: Place a dust cap on cylinder valve outlet whenever the cylinder is not in use. Only install the type of dust cap on the cylinder valve outlet that is provided with the cylinder valve. Other types of caps or plugs may result in leakage of propane.
- If the following information is not followed exactly, a fire causing death or serious injury may occur.
- Do not store a spare LP gas cylinder under or near this outdoor cooking gas appliance.
  - Never fill the cylinder beyond 80 percent full.

**SAVE THESE INSTRUCTIONS**

# INSTALLATION REQUIREMENTS

## Tools and Parts

Gather the required tools and parts before starting installation. Read and follow the instructions provided with any tools listed here.

### Tools Needed

- Phillips screwdriver
- Wrench or pliers
- Pipe wrench
- Scissors or cutting pliers (to remove tiedowns)
- Noncorrosive leak-detection solution

### Parts Supplied

- Gas pressure regulator/hose assembly set for 11" WCP LP gas
- Right side shelf with sear burner
- Left side shelf
- Side shelf push bar
- Side shelf push bar seat (2)
- Searing side burner control knob
- "AA" Batteries (3)
- Warming rack
- Cooking grid
- Side burner cooking grid
- Natural gas orifice for rotisserie/infrared burner

### Parts Needed

- 20 lb LP gas fuel tank - approximately 18" (45.7 cm) height

### Parts Needed for Conversion to Natural Gas

- Natural gas conversion kit Part Number 710-0003. See "Assistance" section to order. The conversion kit includes:
  - Natural gas regulator 4" W.C. (marked "Natural Gas Regulator")
  - 10 ft (3.0 m) Natural gas hose with quick connector
  - 5.9" (150 mm) Natural gas regulator hose
  - 6 mm nut driver
  - 6 mm wrench
  - Hex key
- Gas line shutoff valve
- ½" male pipe thread nipple for connection to pressure regulator.
- LP gas-resistant pipe-joint compound
- CSA design-certified outdoor flexible stainless steel appliance connector (4-5 ft [1.2-1.5 m]) or rigid gas supply line as needed.

## Location Requirements

### ⚠ WARNING



#### Explosion Hazard

**Do not store fuel tank in a garage or indoors.**

**Do not store grill with fuel tank in a garage or indoors.**

**Failure to follow these instructions can result in death, explosion, or fire.**

### ⚠ WARNING



#### Fire Hazard

**Do not use grill near combustible materials.**

**Do not store combustible materials near grill.**

**Doing so can result in death or fire.**

Select a location that provides minimum exposure to wind and traffic paths. The location should be away from strong draft areas.

Do not obstruct flow of combustion and ventilation air.

Clearance to combustible construction for freestanding outdoor grills:

- A minimum of 24" (61 cm) must be maintained between the front of the grill hood, sides and back of the grill and any combustible construction.
- A 24" (61 cm) minimum clearance must also be maintained below the cooking surface, and the grill shall not be used under overhead combustible construction.

### Rotisserie (accessory)\*

If you equip your grill with a rotisserie, a 6" (15.2 cm) minimum clearance is needed for the rotisserie motor.

A grounded, 3-prong outlet located to the left of the grill is required.

\*See "Assistance" section to order.

## Product Dimensions

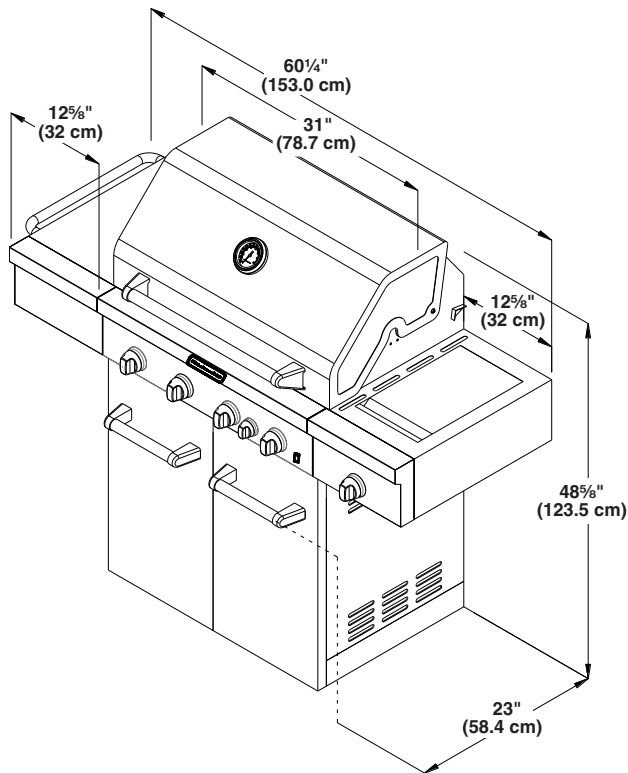

## Electrical Requirements

### ⚠ WARNING



#### Electrical Shock Hazard

Use only a UL listed, 14 gauge, 3 wire extension cord approved for outdoor use, marked W-A, with a maximum length of 50 ft.

Plug into a grounded 3 prong outlet.

Do not remove ground prong.

Do not use an adapter.

Failure to follow these instructions can result in death, fire, or electrical shock.

If codes permit and a separate ground wire is used, it is recommended that a qualified electrician determine that the ground path is adequate.

Check with a qualified electrician if you are not sure whether the grill is properly grounded.

A 120-volt, 60-Hz, AC-only, 15-amp, fused electrical supply is required.

It is recommended that a separate circuit servicing only this grill be provided.

- To avoid electrical shock, do not immerse cord or plugs in water or other liquid.
- Unplug from the outlet when not in use and before cleaning. Allow to cool before putting on or taking off parts.

- Do not operate any outdoor cooking gas appliance with a damaged cord, damaged plug, or after the appliance malfunctions or has been damaged in any manner. Contact the manufacturer for repair.
- Do not let the cord hang over the edge of a table or touch hot surfaces.
- Do not use an outdoor cooking appliance for purposes other than intended.
- When connecting, first connect plug to the outdoor cooking gas appliance then plug appliance into the outlet.
- Use only a Ground Fault Interrupter (GFI) protected circuit with this outdoor cooking gas appliance.
- Do not remove the ground prong or use with an adapter of 2 prongs.
- Use only extension cords with a 3 prong grounding plug rated for the power of the equipment and approved for outdoor use with a W-A marking.

The model/serial number rating plate is located on the inside of the left cabinet door. See the following illustration.

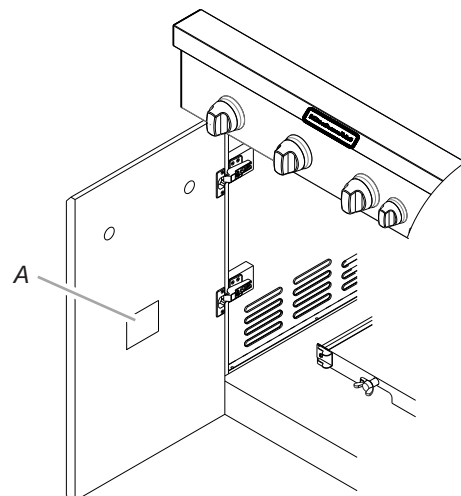

A. Model/serial number plate

## Recommended Ground Method

The outdoor grill, when installed, must be electrically grounded in accordance with local codes or, in the absence of local codes, with the National Electrical Code ANSI/NFPA 70, or Canadian Electrical Code, CSA C22.1.

Copies of the standards listed above may be obtained from:

CSA International  
8501 East Pleasant Valley Rd.  
Cleveland, Ohio 44131-5575

National Fire Protection Association  
One Batterymarch Park  
Quincy, Massachusetts 02269

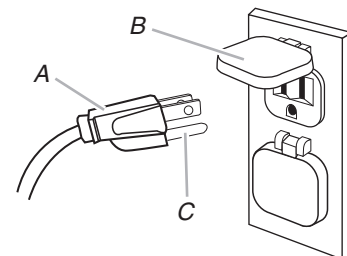

A. 3-prong ground plug  
B. 3-prong polarized type outdoor GFI outlet  
C. Ground prong

## Gas Supply Requirements

### **⚠ WARNING**



#### Explosion Hazard

Use a new CSA International approved “outdoor” gas supply line.

Securely tighten all gas connections.

If connected to LP, have a qualified person make sure gas pressure does not exceed 11” (28 cm) water column.

Examples of a qualified person include:

licensed heating personnel,  
authorized gas company personnel, and  
authorized service personnel.

Failure to do so can result in death, explosion, or fire.

Observe all governing codes and ordinances.

**IMPORTANT:** This installation must conform with all local codes and ordinances. In the absence of local codes, installation must conform with either the National Fuel Gas Code, ANSI Z223.1/ NFPA 54, Natural Gas and Propane Installation Code, CSA B149.1, Propane Storage and Handling Code, B149.2, or the Standard for Recreational Vehicles, ANSI A119.2/NFPA 1192 and CSA Z240 RV Series Recreational Vehicle Code as applicable.

**IMPORTANT:** Grill must be connected to a regulated gas supply.

Refer to the model/serial rating plate for information on the type of gas that can be used. If this information does not agree with the type of gas available, check with your local gas supplier.

#### Gas Conversion:

No attempt shall be made to convert the grill from the gas specified on the model/serial rating plate for use with a different gas type without consulting the serving gas supplier. The conversion kit supplied with grill must be used. See “Gas Conversions” section for instructions.

### Gas Pressure Regulator

The gas pressure regulator supplied with this grill must be used. The inlet (supply) pressure to the regulator should be as follows for proper operation:

#### LP Gas:

Operating pressure: 11" (27.9 cm) WCP

Inlet (supply) pressure: 11" to 14" (27.9 cm to 35.5 cm) WCP

#### Natural Gas:

Operating pressure: 4" (10.2 cm) WCP

Inlet (supply) pressure: 7" to 14" (17.8 cm to 35.5 cm) WCP maximum.

Contact local gas supplier if you are not sure about the inlet (supply) pressure.

### Burner Requirements for High Altitude

Input ratings shown on the model/serial rating plate are for elevations up to 2,000 ft (609.6 m).

For elevations above 2,000 ft (609.6 m), ratings are reduced at a rate of 4% for each 1,000 ft (304.8 m) above sea level. Orifice conversion is required. See “Assistance” section to order.

### Gas Supply Line Pressure Testing

#### Testing above ½ psi (3.5 kPa) or 14" (35.5 cm) WCP (gauge):

The grill and its individual shutoff valve must be disconnected from the gas supply piping system during any pressure testing of that system at test pressures greater than ½ psi (3.5 kPa).

#### Testing below ½ psi (3.5 kPa) or 14" (35.5 cm) WCP (gauge) or lower:

The grill must be isolated from the gas supply piping system by closing its individual manual shutoff valve during any pressure testing of the gas supply piping system at test pressures equal to or less than ½ psi (3.5 kPa).

## Gas Connection Requirements

### 20 lb LP Gas Fuel Tank

This grill is equipped for use with a 20 lb LP gas fuel tank (fuel tank not supplied). A gas pressure regulator/hose assembly is supplied.

Any brand of 20 lb LP gas fuel tank is acceptable for use with the grill, provided that it is compatible with the grill’s retention means (tank tray included).

It is also design-certified by CSA International for local LP gas supply or for Natural gas with appropriate conversion.

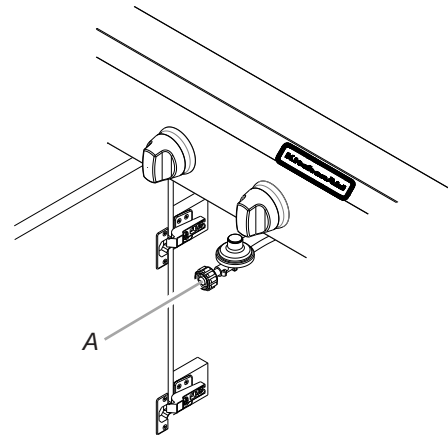

A. Gas pressure regulator/hose assembly

The 20 lb LP gas fuel tank must be mounted and secured.

#### Door Style Tank Tray

1. Open cabinet doors.
2. Slide the tank tray locking bracket counterclockwise 90° and pull out the tray.

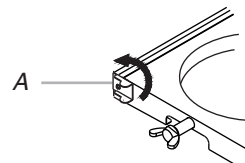

A. Tank tray locking bracket

- Place the 20 lb LP gas fuel tank bottom collar into the mounting hole in the tank tray.
- Tighten the locking screw against the bottom collar of the 20 lb LP gas fuel tank to secure.

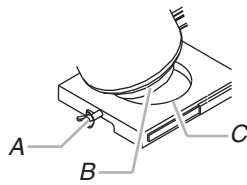

A. Locking screw  
B. Bottom collar  
C. Mounting hole

- Slide the drawer with the 20 lb LP gas fuel tank back into the cabinet. Turn the tank tray locking bracket clockwise 90° to tighten.

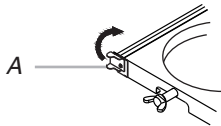

A. Tank tray locking bracket

## Natural Gas Conversion

Conversion must be made by a qualified gas technician. The qualified Natural gas technician shall provide the Natural gas supply to the selected grill location in accordance with the National Fuel Gas Code ANSI Z223.1/NFPA 54 - latest edition, and local codes. For conversion to Natural gas, the Natural Gas Conversion Kit supplied with the grill (on some models) or the Natural Gas Conversion Kit Part Number 710-0003 must be used. See "Assistance" section for information on ordering.

**IMPORTANT:** The gas installation must conform with local codes, or in the absence of local codes, with the National Fuel Gas Code, ANSI Z223.1/NFPA 54 - latest edition.

Follow instructions for converting to Natural gas in the "Gas Conversions" section of this manual or the instructions supplied with Natural Gas Conversion Kit Part Number 710-0003.

The gas supply line shall be equipped with an approved shutoff valve. This valve should be located in the same area as the grill and should be in a location that allows ease of opening and closing. Do not block access to the shutoff valve. The valve is for turning on or shutting off gas to the grill.

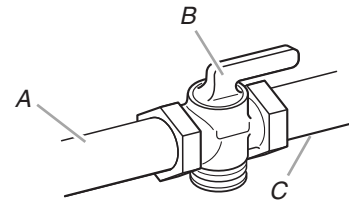

A. Gas supply line  
B. Shutoff valve "open" position  
C. To grill



# REPLACEMENT PARTS

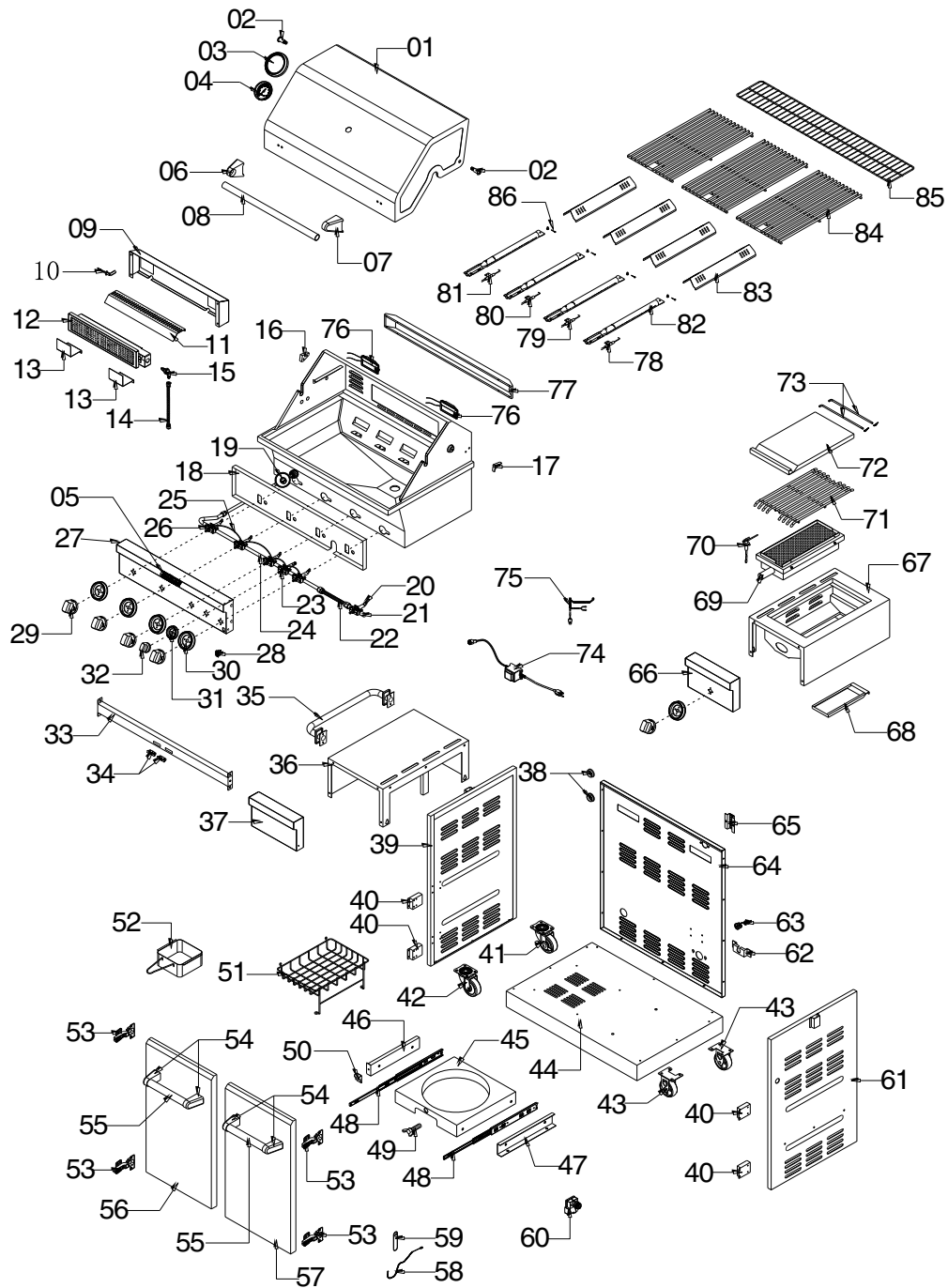

Part Number	Part (description)	Warranty Coverage	Quantity
01	Main lid	3	1
02	Main lid screw	3	2
03	Temperature gauge housing	1	1
04	Temperature gauge	1	1
05	Logo	1	1
06	Main lid handle seat, left	1	1
07	Main lid handle seat, right	1	1
08	Main lid handle tube	1	1
09	Rear baffle	1	1
10	Rotisserie burner ignition wire	1	1
11	Rotisserie heat shield	1	1
12	Rotisserie burner	1	1
13	Rotisserie burner igniter bracket	1	2
14	Rotisserie burner flex gas line	1	1
15	Rotisserie burner with brass elbow	1	1
16	Main lid bracket, left	1	1
17	Main lid bracket, right	1	1
18	Front baffle	1	1
19	Regulator, LP	1	1
20	Sear gas valve	3	1
21	Side manifold	1	1
22	Side burner flex gas line	1	1
23	Rotisserie gas valve	3	1
24	Main manifold	1	1
25	Igniter junction wire	1	1
26	Main gas valve	3	4
27	Main control panel	3	1
28	Light switch	1	1
29	Control knob	1	5
30	Bezel	1	5
31	Control knob bezel, rotisserie burner	1	1
32	Control knob, rotisserie burner	1	1
33	Cart frame, front	1	1
34	Door magnet	1	2
35	Push bar, side shelf	3	1
36	Side shelf, left	3	1
37	Side shelf front panel, left	3	1
38	Rubber grommet	1	3
39	Side panel, left	3	1

Part Number	Part (description)	Warranty Coverage	Quantity
40	Door hinge bracket	1	4
41	Swivel caster with brake	1	1
42	Swivel caster	1	1
43	Caster	1	2
44	Bottom panel	1	1
45	Tank tray	1	1
46	Gas tank tray slide bracket, left	1	1
47	Gas tank tray slide bracket, right	1	1
48	Gas tank tray slide	1	2
49	Tank tray bolt	1	1
50	Gas tank tray block piece	1	1
51	Cart basket	1	1
52	Grease box	1	1
53	Door hinge	1	4
54	Door handle seat	1	4
55	Door handle tube	1	2
56	Door, left	3	1
57	Door, right	3	1
58	Lighting rod	1	1
59	Lighting rod cover	1	1
60	Electric igniter module	1	1
61	Side panel, right	3	1
62	Cable strainer securing plate	1	1
63	Cable strainer	1	1
64	Back panel	3	1
65	Igniter wire cover	1	1
66	Side burner control panel, right	3	1
67	Side burner bowl assembly	1	1
68	Side burner grease tray	1	1
69	Sear burner	1	1
70	Sear burner igniter wire	1	1
71	Sear burner cooking grid with hole	3	1
72	Side burner lid	3	1
73	Side burner lid hinge rod	1	2
74	Transformer	1	1
75	Lamp cord	1	1
76	Lamp	1	2
77	Lamp case	1	1
78	Main burner igniter wire A	1	1
79	Main burner igniter wire B	1	1

<b>Part Number</b>	<b>Part (description)</b>	<b>Warranty Coverage</b>	<b>Quantity</b>
80	Main burner igniter wire C	1	1
81	Main burner igniter wire D	1	1
82	Main burner	5	4
83	Flame tamer	3	4
84	Cooking grid with hole	3	3
85	Warming rack	3	1
86	Burner pin assembly	1	4

<b>Part Number</b>	<b>Part (description)</b>	<b>Warranty Coverage</b>	<b>Quantity</b>
	Natural gas orifice rack		
	Preassembly hardware		
	Manual		
	Carton body		
	Carton lid		
	Carton bottom		

## All Pre-Assembled Screws List

Sort	Description	Size	Quantity
1	1/4 Screw (with washer)	1/4*12mm	16
2	5/32 Screw (with washer)	5/32*12mm	5
3	M4 Screw (with washer)	M4*8mm	2
4	5/32 Screw	5/32*12mm	4
5	5/32 Flat washer		6
6	5/32 Lock nut		2

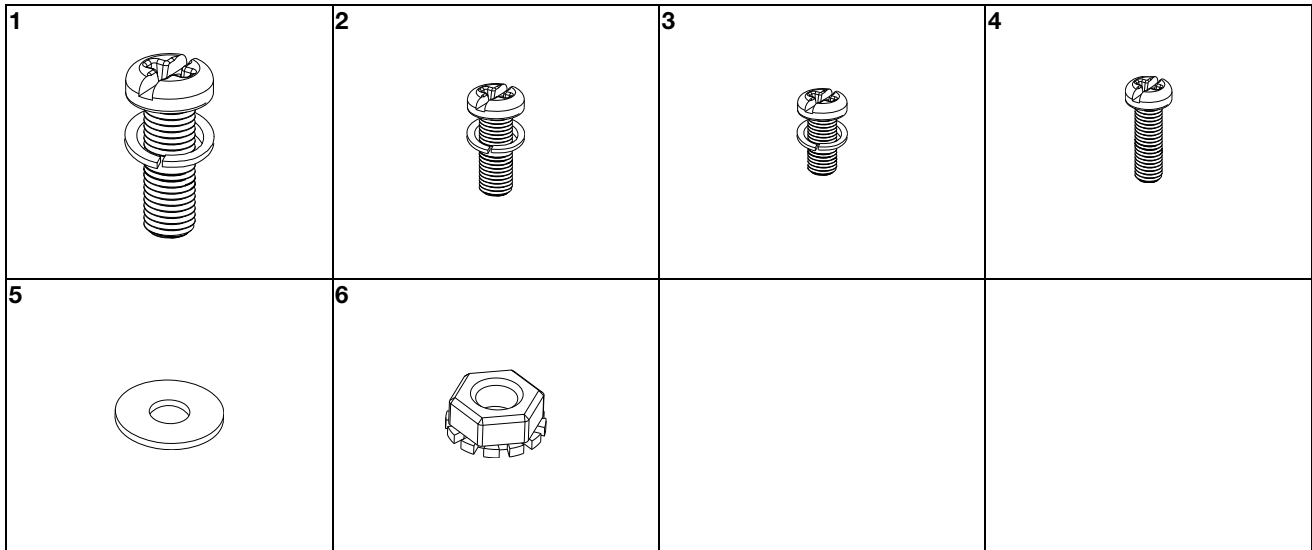

## Package Content List

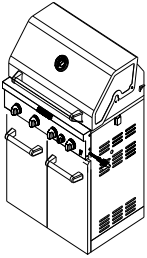
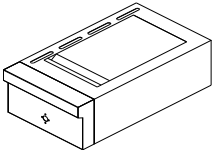
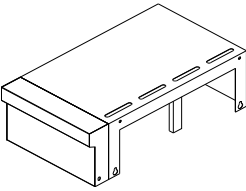
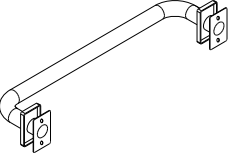
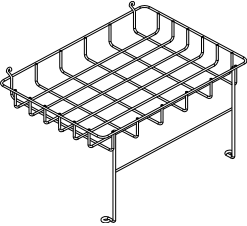
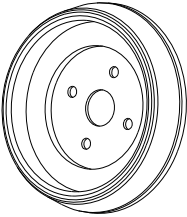
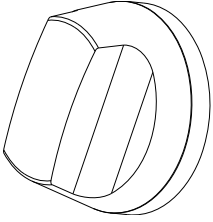
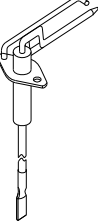
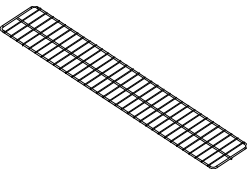
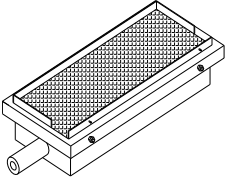
	<b>Side Burner Assembly</b> 	<b>Side Shelf Assembly</b> 	<b>Push Bar</b> 
<b>Wire Basket</b> 	<b>Bezel</b> 	<b>Control Knob</b> 	<b>Side Burner Ignitor</b> 
<b>Warming Rack</b> 	<b>Searing Burner</b> 		

# INSTALLATION INSTRUCTIONS

## Freestanding Outdoor Grill Installation

### **⚠ WARNING**

#### **Excessive Weight Hazard**

Use two or more people to move and install grill.  
Failure to do so can result in back or other injury.

#### **Unpack Grill**

1. Remove all packaging materials and remove grill from the shipping base.
2. Move grill close to desired outdoor location.
3. Open the grill hood.

#### **Remove Packaging Material Inside the Grill**

1. Use a utility knife to cut yellow straps and packing tape to open box from top and remove the boxes.
2. Remove the warming shelf and grill grates from inside the grill and remove the package inside the firebox.
3. Remove foam block and wrap from inside the grill.

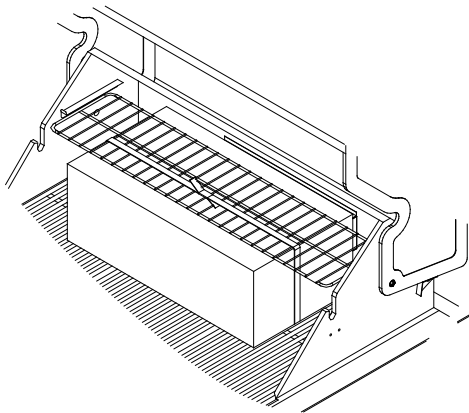

#### **Attach Right Side Shelf with Sear Burner**

1. Unpack right side shelf with sear burner.
2. Open grill lid.
3. Remove 3 screws from the side of the searing side burner.

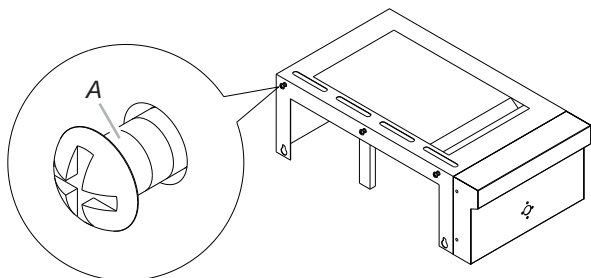

A. Searing side burner screws

4. Remove the screws from the central post, then 2 screws on the grill side panel and 1 screw on the grill control panel.

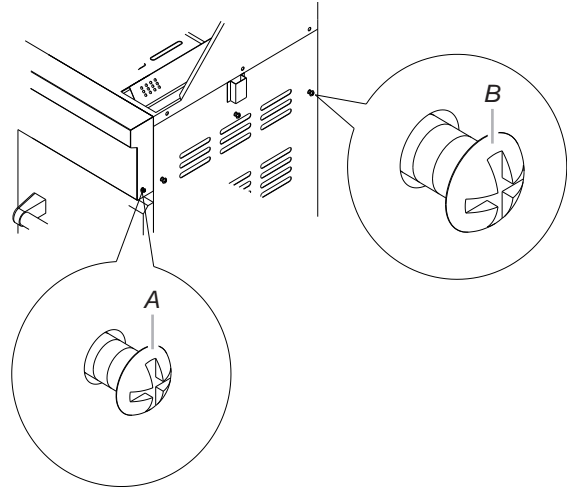

A. Grill control panel screw  
B. Grill side panel screws

5. Lower the side shelf so that the center post (A) slides into the bracket (B) and align the bottom keyhole slots on the side shelf with the screw holes on the grill side panel.

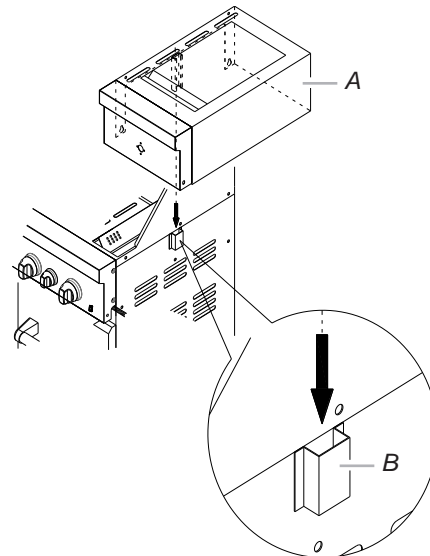

**IMPORTANT:** This step is meant to help with the installation, but do not depend solely on the bracket to hold the weight of the sear burner.

6. Attach the top of the side shelf to the grill (A) by inserting the 3 screws removed in Step 3 into the side shelf from inside the grill hood and tighten. See illustration in Step 8.
7. Attach the bottom of the side shelf to the side panel (B and C) of the grill by inserting the 3 screws removed from the grill side panel in Step 4. The drip pan may need to be pulled forward to install the center screw (C). Tighten the screws. See illustration in Step 8.

8. Attach the side shelf to the control panel (D) by inserting the screw removed from the grill control panel in Step 4. Tighten the screw.

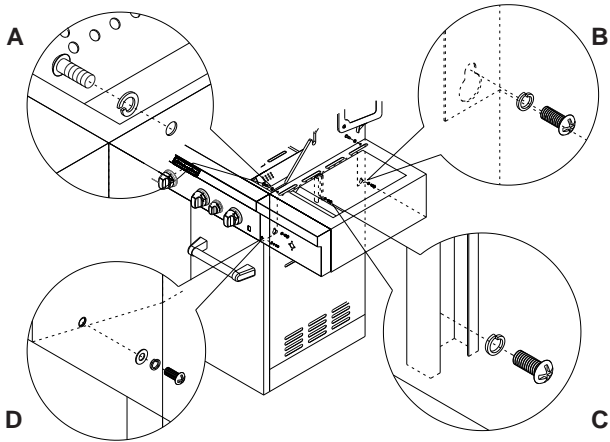

9. Remove the 3 screws from the searing side burner.

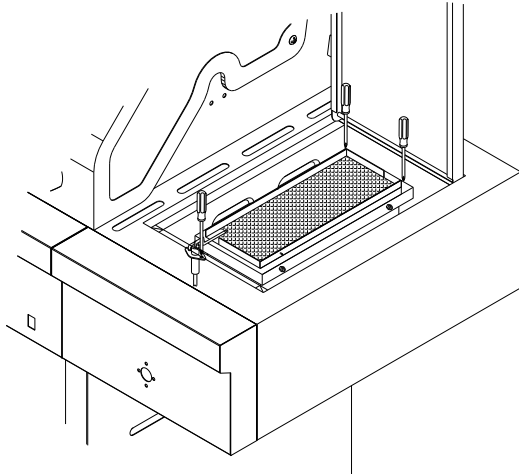

10. Remove the searing side burner.

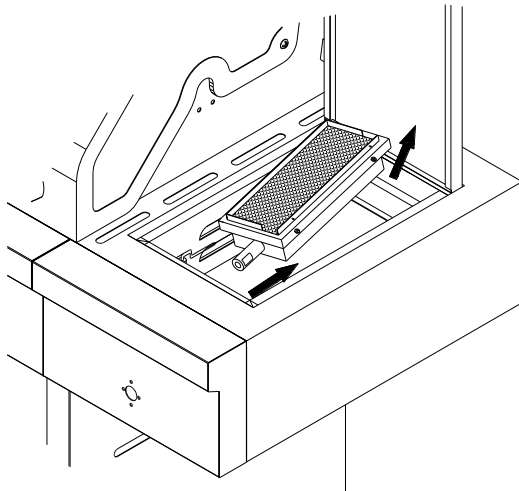

11. Remove the 2 screws from the side burner valve assembly. See illustration in Step 13.

12. Push the valve stem out through the opening in the front of the side burner shelf, lining up the holes in the side burner valve assembly with the openings on the side burner shelf. See illustration in Step 13.

13. Slide the bezel opening over the valve stem and attach the side burner valve assembly and bezel to the side burner shelf with the screws removed in Step 11.

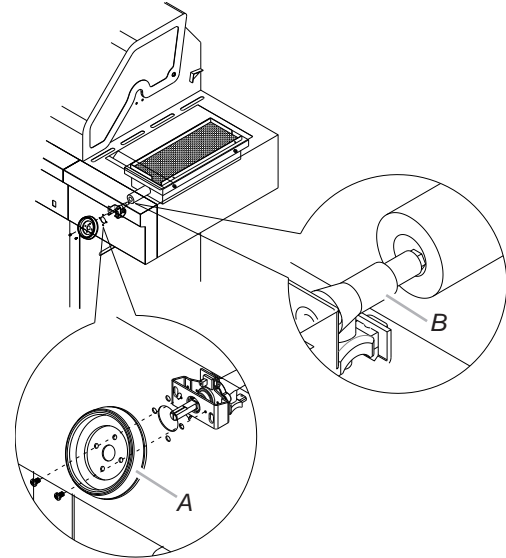

A. Bezel  
B. Valve stem

14. Replace the searing side burner, angling it so that the side burner tube slides over the valve orifice. Locked 3 screws removed in step 9.

15. Connect electrical plugs on underside of sear burner.

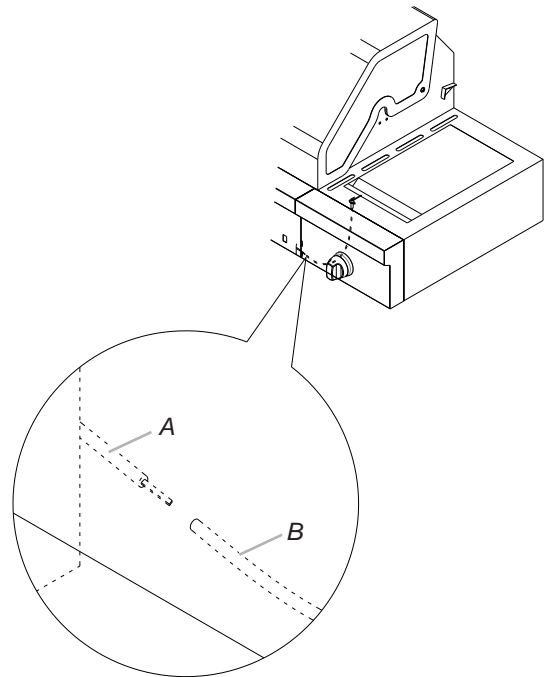

A. Electrical plug from grill  
B. Electrical plug from sear burner

16. Insert the valve stem into the knob and push knob into place.

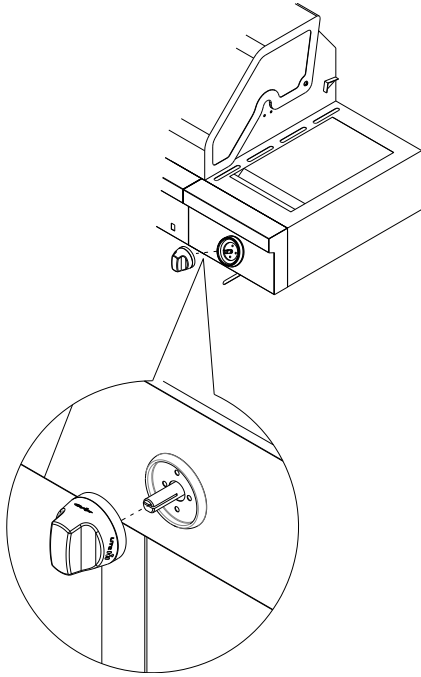

17. The igniter battery is not factory installed. A “AA” size alkaline battery is located in the accessory box on the grill grate. Install battery at this time following the instructions in “Replacing the Igniter Battery” section.

### Attach Left Side Shelf

1. Unpack left side shelf.
2. Open grill lid.
3. Remove 3 screws from the side of the side shelf.

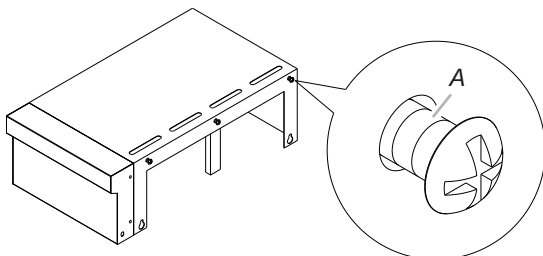

A. Side shelf screws

4. Remove the screw from the central post, then 2 screws from the grill side panel and 1 screw on the grill control panel.

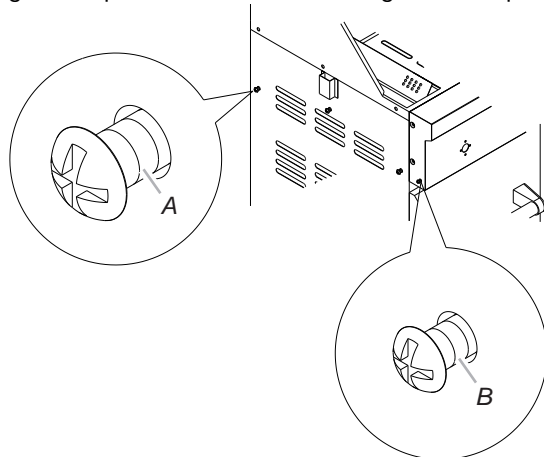

A. Grill side panel screws  
B. Grill control panel screw

5. Lower the side shelf so that the side shelf center post (A) slides into the bracket (B) and align the bottom keyhole slots on the side shelf with the screw holes on the grill side panel.

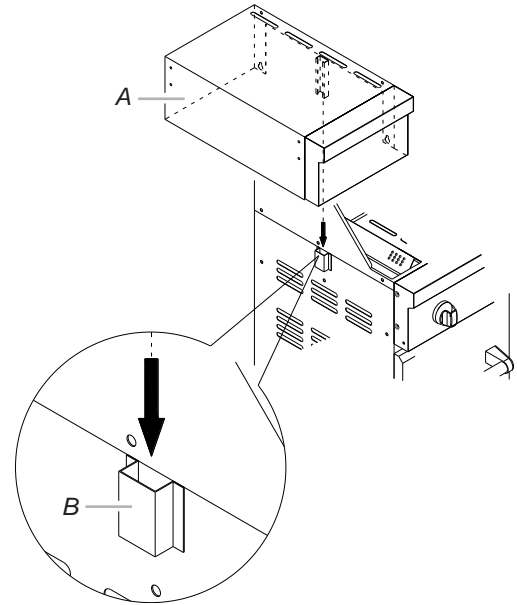

**IMPORTANT:** This step is meant to help with the installation, but do not depend solely on the bracket to hold the weight of the side shelf.

6. Attach the top of the side shelf to the grill (B) by inserting the 3 screws removed in Step 3 into the side shelf from inside the grill hood and tighten. See illustration in Step 8.
7. Attach the bottom of the side shelf to the side panel (A and D) of the grill by inserting the 3 screws removed from the grill side panel in Step 4. The drip pan may need to be pulled forward to install the center screw (D). Tighten the screws. See illustration in Step 8.
8. Attach the side shelf to the control panel (C) by inserting the screw removed from the grill control panel in Step 4. Tighten the screw.

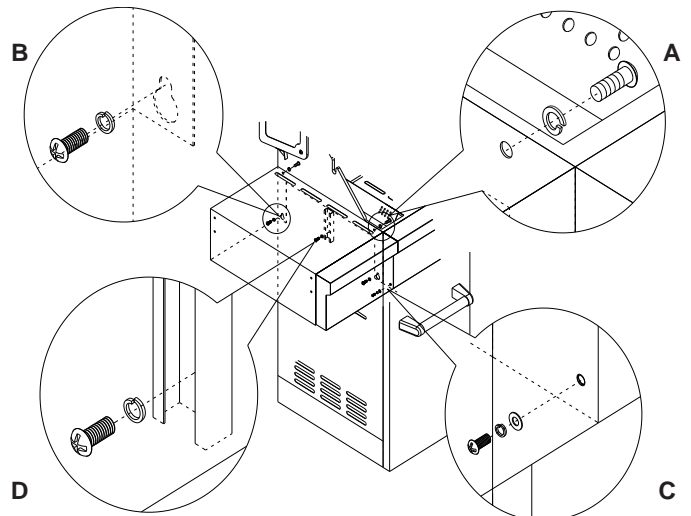



9. Make sure that the push bar screw cover is separated from the the screw plate.

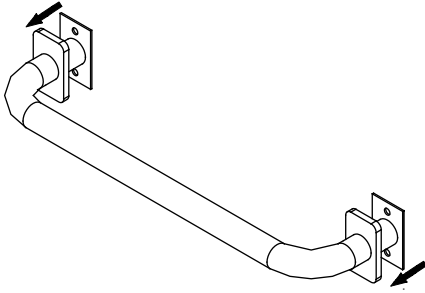

10. Remove the 2 screws and washers from the side of left side shelf. Attach side shelf push bar by aligning the screw holes on the side shelf with the screw holes in the push bar. Insert the screws into the push bar screw holes and then into the side shelf and tighten. Push in the push bar screw covers on both sides to cover the screws.

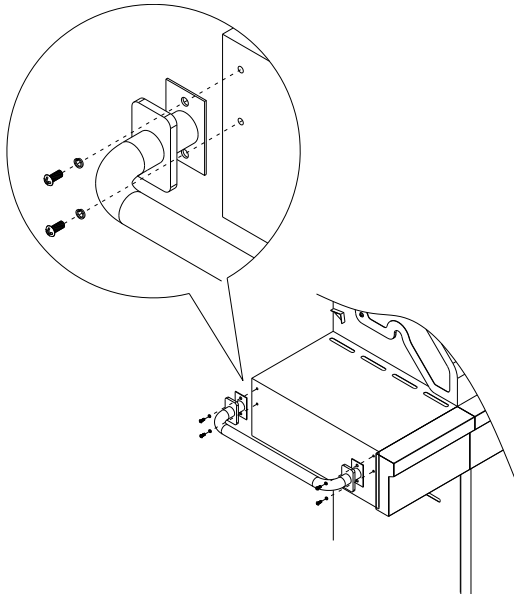

### Complete Assembly

1. Replace the grill grates.
2. Place warming shelf on brackets as shown..

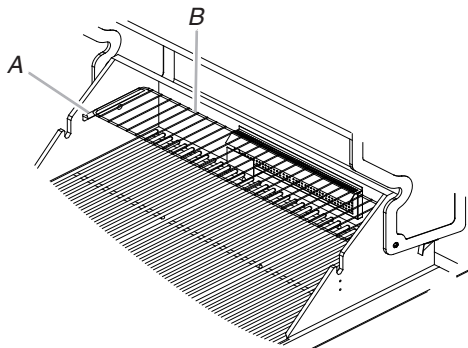

A. Warming shelf brackets  
B. Warming shelf

### Attach Cart Basket

1. Remove 2 screws on the side panel and 2 screws on the bottom panel.
2. Attach basket to the side panel and bottom panel by using the screws removed in step 1.

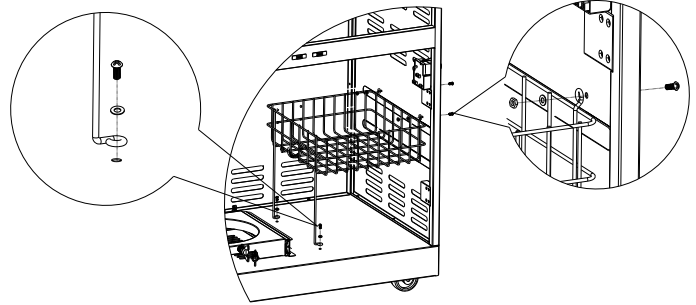

### Make Gas Connection

**NOTE:** If grill is to be converted to Natural gas, follow instructions in the "Gas Conversions" section.

### 20 lb LP Gas Fuel Tank

## ⚠ WARNING



### Explosion Hazard

Securely tighten all gas connections.

If connected to LP, have a qualified person make sure gas pressure does not exceed 11" (28 cm) water column.

Examples of a qualified person include:  
licensed heating personnel,  
authorized gas company personnel, and  
authorized service personnel.

Failure to do so can result in death, explosion, or fire.

### LP Gas:

**IMPORTANT:** A 20 lb LP gas fuel tank must be purchased separately.

**IMPORTANT:** The gas pressure regulator/hose assembly supplied with the grill must be used. Replacement gas pressure regulator/hose assembly specific to your model, is available from your outdoor grill dealer.

### Door Style Tank Tray

1. Open cabinet doors.
2. Slide the tank tray locking bracket counterclockwise 90° and pull out the tray.

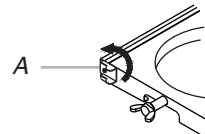

A. Tank tray locking bracket

3. Place the 20 lb LP gas fuel tank bottom collar into the mounting hole in the tank tray.
4. Tighten the locking screw against the bottom collar of the 20 lb LP gas fuel tank to secure.

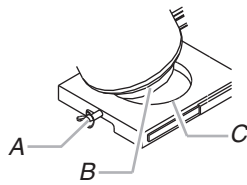

A. Locking screw  
B. Bottom collar  
C. Mounting hole

5. Slide the tank tray with the 20 lb LP gas fuel tank back into the cabinet and lock the locking bracket.

**To Connect the 20 lb LP Gas Fuel Tank:**

1. Check that the 20 lb LP gas fuel tank is in the “Off” position. If not, turn the valve clockwise until it stops.
2. Check that the 20 lb LP gas fuel tank valve has the proper type-1 external male thread connections per ANSI Z21.81.
3. Check that the burner control knobs are in the “Off” position.
4. Remove any debris and inspect the valve connections, port, and gas pressure regulator/hose assembly for damage.

**NOTE:** Always keep the LP cylinder at 90° (upright) orientation to provide vapor withdrawal.

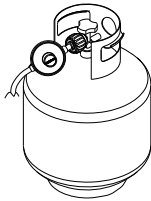

5. Using your hand, turn the gas pressure regulator/hose assembly clockwise to connect to the 20 lb LP gas fuel tank as shown.  
Hand tighten only. Use of a wrench could damage the quick coupling nut.

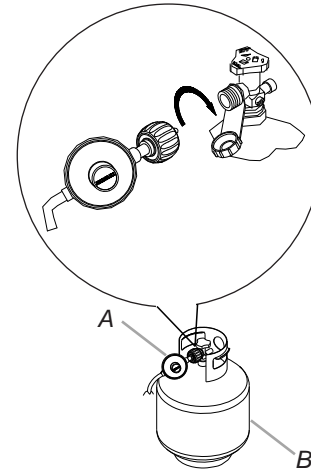

A. Gas pressure regulator/hose assembly  
B. 20 lb LP gas fuel tank

Make sure that the cylinder valve connection device properly mates with the connection device attached to the inlet of the pressure regulator.

6. Open the tank valve fully by turning the valve counterclockwise. Wait a few minutes for gas to move through the gas line.
7. Before lighting the grill, test all connections by brushing on an approved noncorrosive leak-detection solution. Bubbles will show a leak.
8. If a leak is found, turn the tank valve off and do not use the grill. Contact a qualified gas technician to make repairs.
9. Go to “Check and Adjust the Burners” section.

### To Disconnect the 20 lb LP Gas Fuel Tank:

1. Check that the burner control knobs are in the "Off" position and the grill is cool.
2. Check that the 20 lb LP gas fuel tank is in the "Off" position. If not, turn the valve clockwise until it stops.
3. Using your hand, turn the gas pressure regulator/hose assembly counterclockwise to disconnect to the 20 lb LP gas fuel tank as shown.

Hand loosen only. Use of a wrench could damage the quick coupling nut.

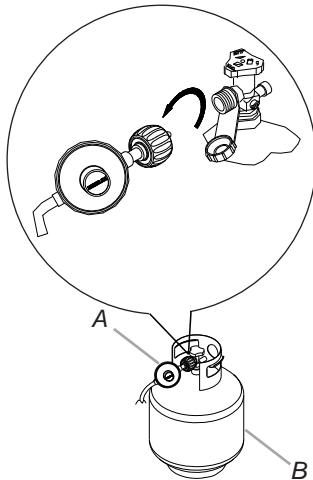

A. Gas pressure regulator/hose assembly  
B. 20 lb LP gas fuel tank

4. Place dust cap on cylinder valve outlet whenever the cylinder is not in use. Only install the type of dust cap on the cylinder valve outlet that is provided with the cylinder valve. Other types of caps or plugs may result in leakage of propane.
5. Go to "Plug in Grill" in this section.

### Plug in Grill

## ⚠ WARNING



### Electrical Shock Hazard

Use only a UL listed, 14 gauge, 3 wire extension cord approved for outdoor use, marked W-A, with a maximum length of 50 ft.

Plug into a grounded 3 prong outlet.

Do not remove ground prong.

Do not use an adapter.

Failure to follow these instructions can result in death, fire, or electrical shock.

1. Plug extension cord into grounded 3-prong GFI outlet.

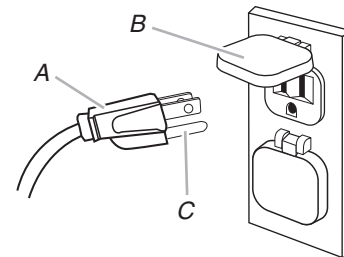

A. 3-prong ground plug  
B. 3-prong polarized type outdoor GFI outlet  
C. Ground prong

- To avoid electrical shock, do not immerse cord or plugs in water or other liquid.
  - Unplug from the outlet when not in use and before cleaning. Allow to cool before putting on or taking off parts.
  - Do not operate any outdoor cooking gas appliance with a damaged cord, damaged plug, or after the appliance malfunctions or has been damaged in any manner. Contact the manufacturer for repair.
  - Do not let the cord hang over the edge of a table or touch hot surfaces.
  - Do not use an outdoor cooking appliance for purposes other than intended.
  - When connecting, first connect plug to the outdoor cooking gas appliance then plug appliance into the outlet.
  - Use only a Ground Fault Interrupter (GFI) protected circuit with this outdoor cooking gas appliance.
  - Do not remove the ground prong or use with an adapter of 2 prongs.
  - Use only extension cords with a 3 prong grounding plug rated for the power of the equipment and approved for outdoor use with a W-A marking.
2. Go to "Check and Adjust the Burners" section.

# GAS CONVERSIONS

## Tools and Parts for Gas Conversion

Gather the required tools and parts before starting installation. Read and follow the instructions provided with any tools listed here.

### Tools needed

- Phillips screwdriver
- Pipe wrench
- Adjustable wrench
- 6 mm socket and wrench or 6 mm nut driver
- Thin flat-blade screwdriver
- Pliers
- Pipe thread sealant certified for LP gas

### Parts supplied

- Natural gas orifices

### Parts needed

- Natural gas conversion kit Part Number 710-0003. See “Assistance” section to order. The conversion kit includes:
  - Natural gas regulator 4" W.C. (marked “Natural Gas Regulator”)
  - 10 ft (3.0 m) Natural gas hose with quick connector
  - 5.9" (150 mm) Natural gas regulator hose
  - 6 mm nut driver
  - 6 mm wrench
  - Hex key

**IMPORTANT:** Gas conversions must be done by a qualified installer. Before proceeding with conversion, shut off the gas supply to the appliance prior to disconnecting the electrical power.

## ⚠ WARNING



### Explosion Hazard

Use a new CSA International approved “outdoor” gas supply line.

Securely tighten all gas connections.

Failure to do so can result in death, explosion, or fire.

## Conversion from LP Gas to Natural Gas

### Installation of the regulator

1. Turn off the main gas supply valve.
2. Unplug grill or disconnect power.
3. Disconnect 20 lb LP gas fuel tank (if present).
4. Turn off all burner control valves.
5. Remove the 20 lb LP gas fuel tank (if present) from the grill cart.

6. Use an adjustable wrench to remove the LP regulator from the manifold.

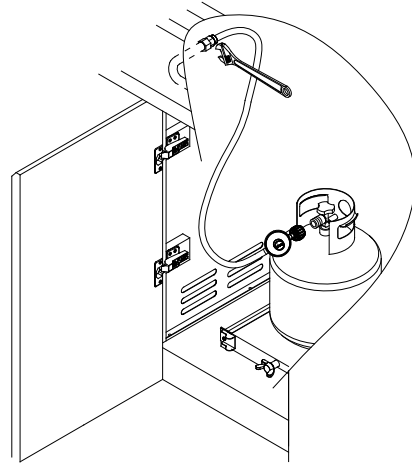

7. Use an adjustable wrench to install the Natural gas regulator hose to the manifold and secure. Attach the Natural gas regulator to the side panel inside the grill cart with the two screws that are preassembled on the regulator.

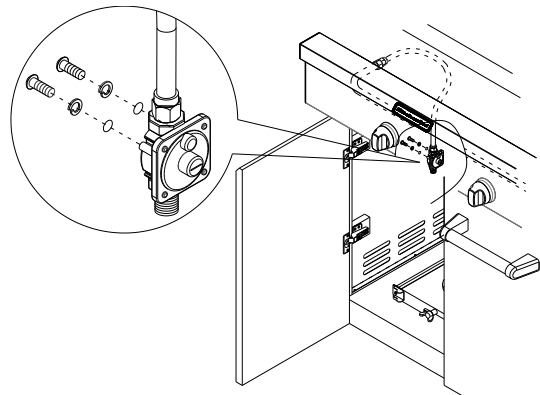

### Make Gas Connection

1. A combination of pipe fittings must be used to connect the grill to the existing gas line.
  - The 10 ft (3.0 m) PVC flexible gas supply hose design-certified by CSA must be used.
  - Pipe-joint compounds suitable for use with Natural gas must be used. Do not use Teflon<sup>†</sup> tape.
  - There must be a certified manual shut-off valve in the gas supply line near the grill for easy access.
2. Connect the brass connector on one end of the 10 ft (3.0 m) PVC flexible gas supply hose to the Natural gas pressure regulator.

<sup>†</sup>TEFLON is a registered trademark of E.I. Du Pont De Nemours and Company.

3. Connect the quick connector on the other end of the 10 ft (3.0 m) PVC flexible gas supply hose to the rigid Natural gas supply pipe.

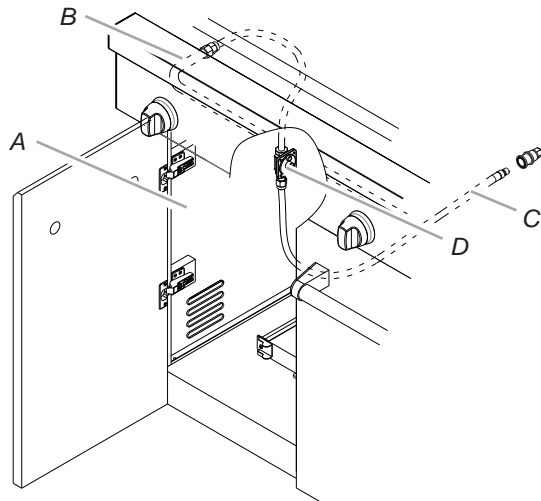

A. Left side panel  
 B. Manifold  
 C. 10 ft. (3.0 m) PVC gas hose  
 D. Natural gas pressure regulator/hose assembly

### Change Grill Burner Valve Orifices

1. Remove the grates and flame tamers.
2. Remove the 1 screw and cotter clip that hold the burner in place. Set the screw and clip aside. Remove the burner from the grill by lifting the burner out.

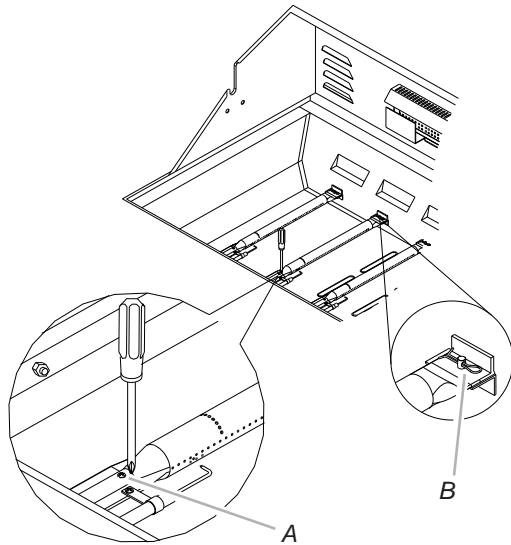

A. Screw  
 B. Cotter clip

3. Use a 6 mm socket and wrench or 6 mm nut driver to remove the brass orifice from the end of gas valve. The main burner orifice is located behind the LP orifice, so no additional orifice needs to be installed.

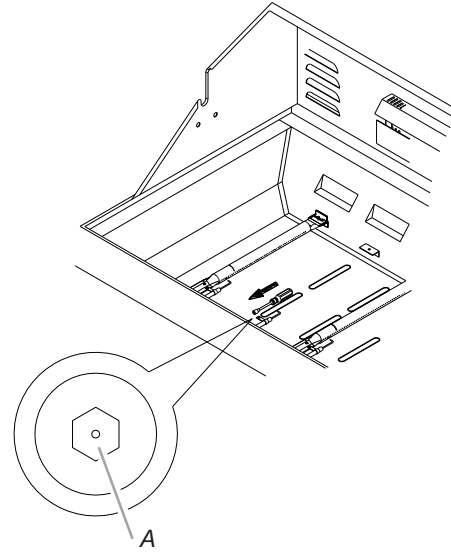

A. Main burner orifice

**IMPORTANT:** Check that the orifice is properly installed inside of the burner opening.

4. Reinsert the burner and reattach using the 2 screws previously removed. Repeat the procedure for each main burner.
5. Position the igniters so they are 1/4" (6.0 mm) away from each burner.

### Change the Rotisserie/Infrared Burner Orifice

1. Using a Phillips screwdriver, unscrew the 2 screws and remove the rotisserie/infrared burner wind baffle.

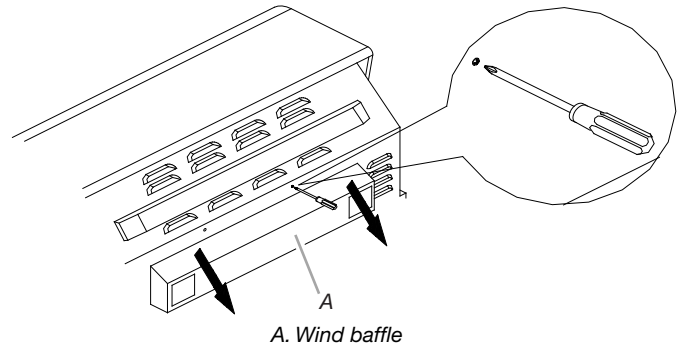

A. Wind baffle

2. Using a Phillips screwdriver, remove the 4 screws at the back of grill from inside the grill (2 screws on each side of the rotisserie infrared burner).

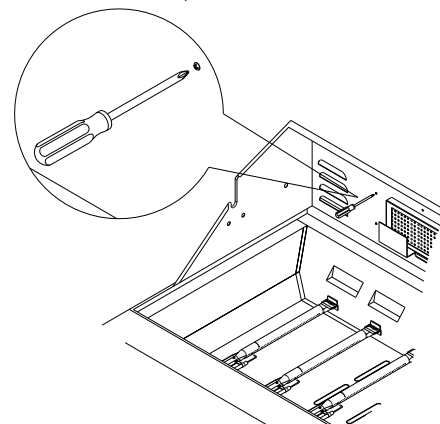

- Remove the access cover at the back of the grill hood by removing the 4 screws (2 screws on each side of the rotisserie infrared burner).

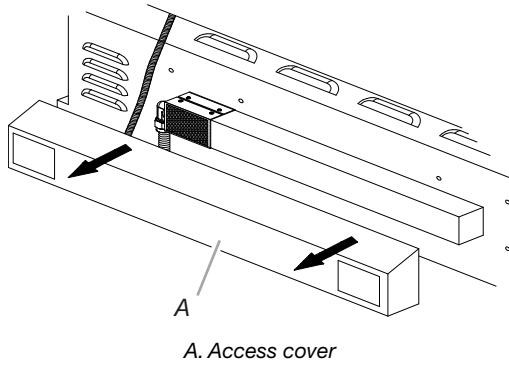

- Using a Phillips screwdriver, remove the 2 screws holding the spider guard to the burner.

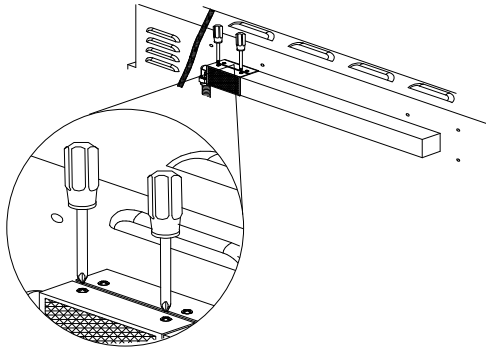

- Use 24 mm wrench to remove the orifice nut.

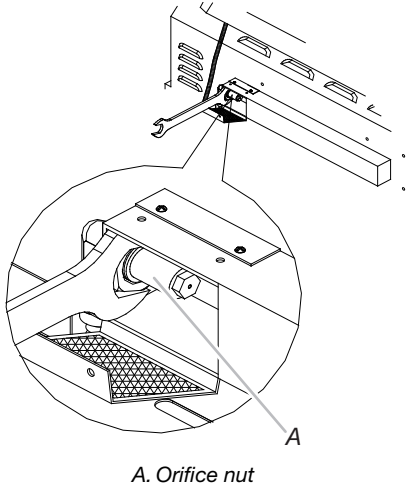

- Take out the orifice support, and then use a 6 mm socket and wrench or 6 mm nut driver to remove the LP orifice at the end of the supply pipe. Replace with Natural gas orifice.

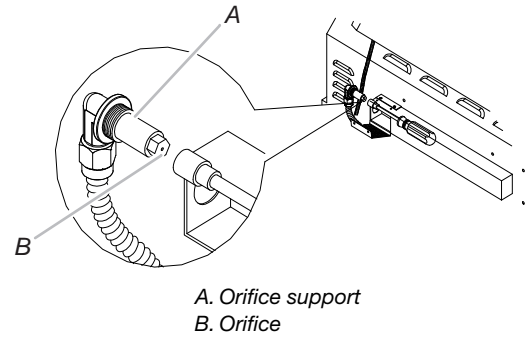

**IMPORTANT:** Check that the orifice is properly installed inside of the supply pipe.

- Reinstall the orifice support and supply pipe and tighten the nut with a 24 mm wrench.
- Reinstall the spider guard, access cover, and wind baffle.

### Change the Sear Burner Orifices

- Remove the screw securing the igniter and the 2 searing side burner screws.

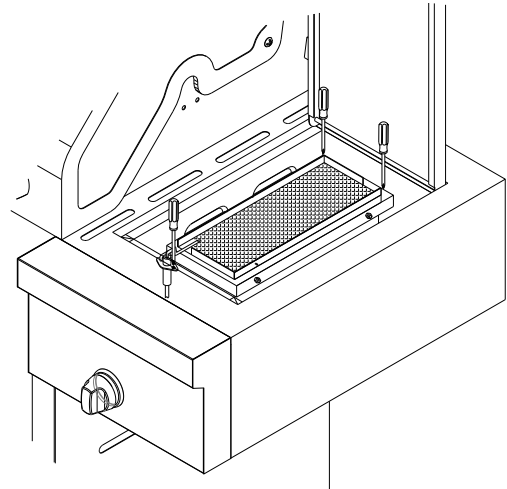

- Lift out the searing side burner.

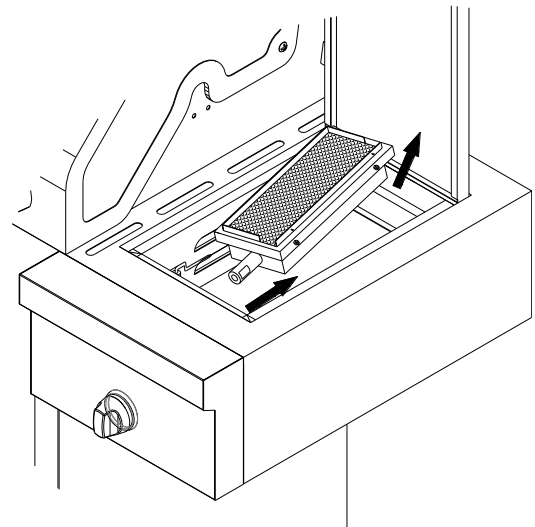

3. Locate the Liquid propane orifice at the end of the valve.

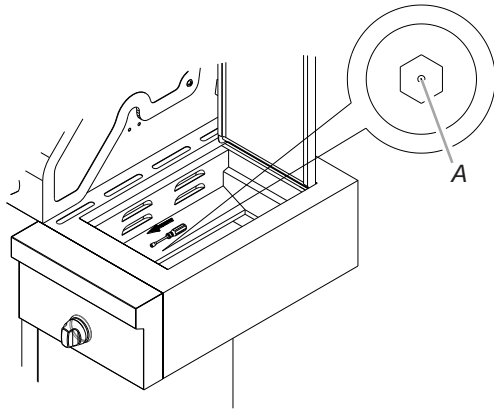

A. Orifice

4. Use 6 mm socket wrench or 6 mm nut driver to remove the orifice. Replace with the Natural gas orifice.

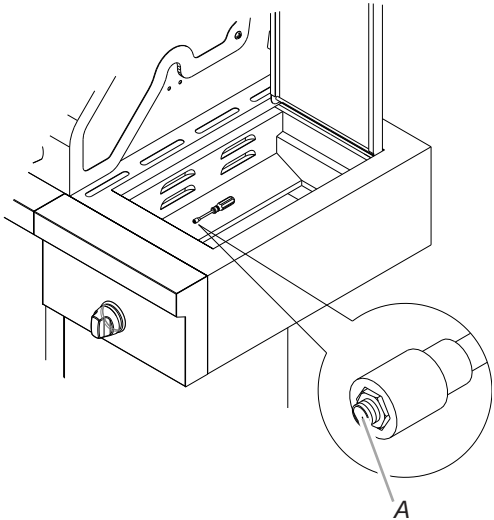

A. Orifice

**IMPORTANT:** Check that the orifice is properly installed inside of the valve.

5. Reinstall the searing side burner. Make sure that the igniter is out of the way to allow proper positioning of burner. Use Phillips screwdriver to attach the mounting screws.
6. Use Phillips screwdriver to reattach the igniter and searing side burner plate.
7. Open the manual shutoff valve in the gas supply line. The valve is open when the handle is parallel to the gas pipe.

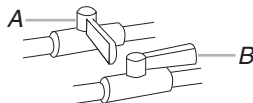

A. Closed valve  
B. Open valve

8. Test all connections using an approved noncorrosive leak-detection solution. Bubbles will show a leak. Correct any leak found.

## Record Conversion

1. The appliance nameplate is located inside the grill cabinet on the left-hand cabinet side. With a permanent marker, check the box next to "Natural gas" and mark through "LP - Propane."

In the last page of the Use and Care Guide, write "Converted to Natural Gas." Also record the conversion date and the technician/company that performed the conversion.

**NOTE:** Place LP gas parts in plastic parts bag for future use and keep with pack containing literature.

## Adjust High Flame Setting Screw

When converting from LP to Natural gas, you will need to adjust the high flame setting screw for ideal burner flame height.

1. Remove each control knob for the main burner and side burner.

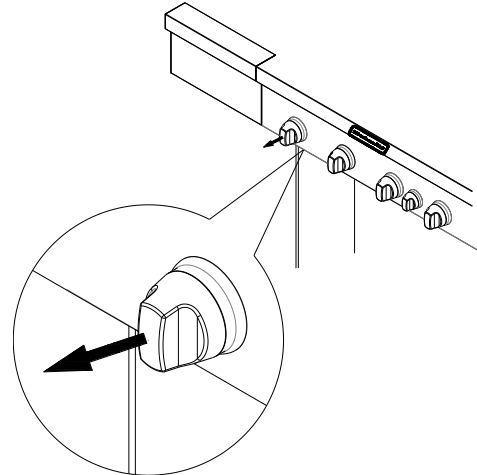

2. Use a flat-blade screwdriver to turn the high flame setscrew counterclockwise approximate 90°.

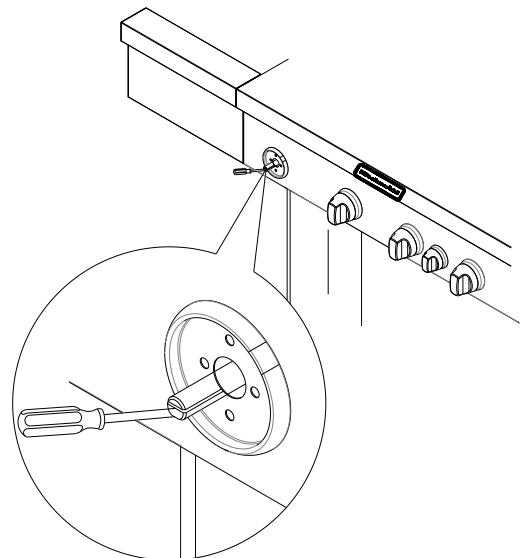

3. Check that burner operates at the new high flame setting. It may be necessary to adjust the screw setting slightly more to get the ideal burner flame height.

## Check and Adjust the Burners

The burners are tested and factory-set for most efficient operation. However, variations in gas supply and other conditions may make minor adjustments to air shutter or low flame setting necessary.

It is recommended that a qualified person make burner adjustments.

**NOTE:** The rotisserie burner cannot be adjusted.

Checking and adjusting the grill burner flames requires removing the grates and flame tamers.

### Burner Flame Characteristics

The flames of the grill burners and side burners (on some models) should be blue and stable with no excessive noise or lifting (LP gas flames will have a slightly yellow tip). A yellow flame indicates not enough air. If flame is noisy or lifts away from the burner, there is too much air. Some yellow tips on flames when the burner is set to HIGH setting are acceptable as long as no carbon or soot deposits appear. The flames should be approximately 1" (2.5 cm) high.

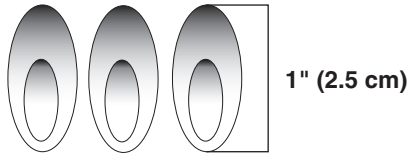

Check that burners are not blocked by dirt, debris, insect nests, etc., and clean burners as necessary. If they are clean, adjust air shutters as needed.

**IMPORTANT:** Before adjusting air shutters, let burners cool completely.

#### To Adjust:

1. Light grill using information in the "Outdoor Grill Use" section.
2. Observe flame to determine which burners need adjustment and how the flame is acting.
3. Turn off the valve and wait until grill and burners cool completely.
4. Remove grill grates and flame tamers.
5. Remove the 1 screw and cotter clip that hold the burner in the place. Remove gas burner from the grill.

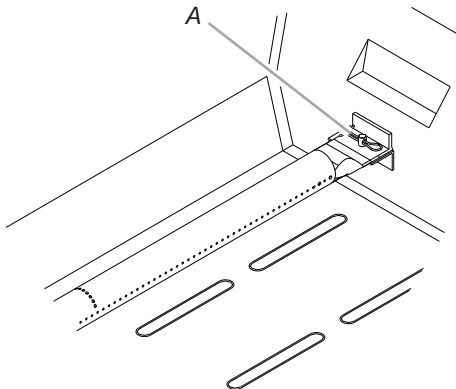

A. Screw

6. If flame is yellow (not enough air), turn air shutter adjustment screw counterclockwise.

If flame is noisy or lifts away from burner (too much air), turn air shutter adjustment screw clockwise.

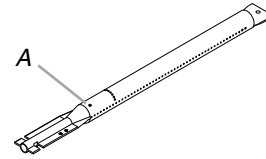

A. Air shutter adjustment screw

Adjustment should be made clockwise or counterclockwise from 1/8" (3.2 mm) to 1/4" (6.4 mm).

7. Replace gas burner, flame tamers and grates.
8. Light grill using information in the "Outdoor Grill Use" section. See "Burner Flame Characteristics."

### Low Flame Adjustment

If flame goes out on the "LOW" setting, the low flame setting must be adjusted.

1. Turn off the valve and wait until grill and burners are cool.
2. Remove grill grates and flame tamers.
3. Light grill using information in the "Outdoor Grill Use" section.
4. Turn burner to its lowest setting.
5. Remove each control knob for the main burner and side burner.
6. Hold valve stem with pliers and insert a small flat-blade screwdriver into the shaft.
7. Watch the flame and slowly turn the screwdriver counterclockwise.
8. Adjust flame to minimum stable flame.

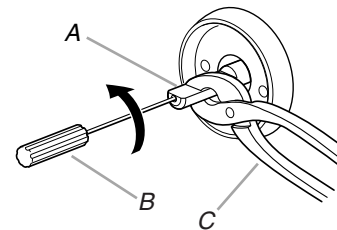

A. Valve stem  
B. Small flat-blade screwdriver  
C. Pliers

9. Replace the control knob and turn off the burner.
10. Repeat steps 3 through 9 for each burner if needed.
11. Replace the flame tamers and grates after the burners have cooled.



# OUTDOOR GRILL USE

This manual covers several different models. The grill you have purchased may have some or all of the features listed. The locations and appearances of the features shown here may not match those of your model.

## Control Panel

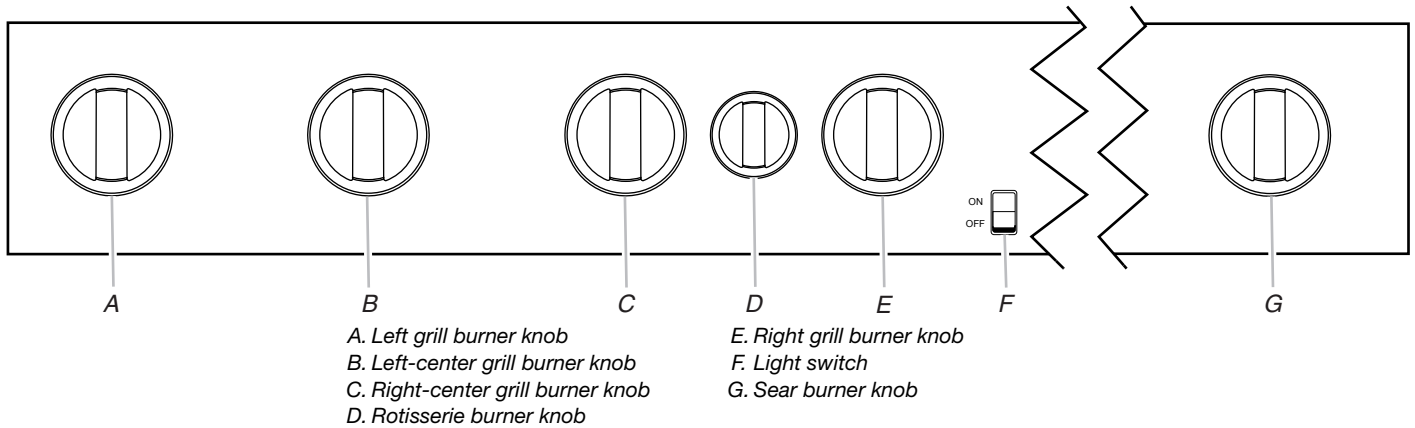

## Using Your Outdoor Grill

### ⚠ WARNING



#### Explosion Hazard

Do not store fuel tank in a garage or indoors.  
 Do not store grill with fuel tank in a garage or indoors.  
 Failure to follow these instructions can result in death, explosion, or fire.

### ⚠ WARNING



#### Fire Hazard

Do not use grill near combustible materials.  
 Do not store combustible materials near grill.  
 Doing so can result in death or fire.

### ⚠ WARNING

#### Food Poisoning Hazard

Do not let food sit for more than one hour before or after cooking.  
 Doing so can result in food poisoning or sickness.

### Inspect the LP Gas Fuel Tank Supply Hose

Inspect the gas pressure regulator/hose assembly before each use.

1. Open left-hand cabinet door.
2. Inspect the gas pressure regulator/hose assembly for cuts, abrasions, or excessive wear.
3. If necessary, replace the gas pressure regulator/hose assembly before using the grill.

Contact the dealer and use only replacement hoses specified for use with the grill.

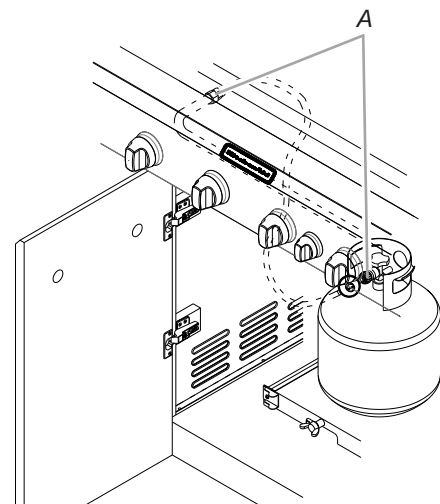

A. Gas pressure regulator/hose assembly

---

## Prepare the Grill for Lighting

---

1. Open the hood completely. Do not light burners with the hood closed.
2. Make sure control knobs are turned to OFF. The drip pan must be in place and pushed all the way to the back.

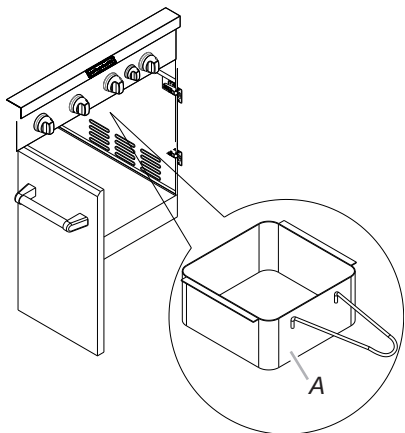

A. Drip pan

---

## Turn the Gas Supply On

---

1. For outdoor grills using a 20 lb LP gas fuel tank:  
Slowly open the tank valve.  
**NOTE:** If flow limiting device activates, your grill may not light. If your grill does light, the flames will be low and will not heat properly. Turn tank valve and all control knobs off and wait 30 seconds. After shutting off the tank, very slowly open tank valve and wait 5 seconds before lighting.
2. For outdoor grills using gas supply source other than 20 lb LP gas fuel tank:  
Open the manual shutoff valve in the gas supply line. The valve is open when the handle is parallel to the gas pipe.

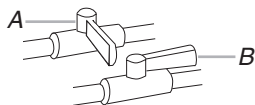

A. Closed valve  
B. Open valve

---

## Lighting the Grill Burners

---

**IMPORTANT:** If burner does not light immediately, turn the burner knob to OFF and wait 5 minutes before relighting.

1. Open the hood completely. Do not light burners with the hood closed.
2. Do not lean over the grill.
3. Select the burner you want to light. Push in and turn the grill burner control knob to IGNITE HIGH, while continuing to hold it in.

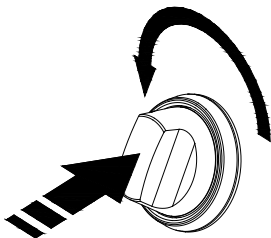

4. You will hear the “snapping” sound of the spark. When burner is lit, release the knob. Turn knob to desired setting.
5. Repeat for each of the other burners as needed.

---

## Manually Lighting the Grill Burners

---

1. Open the hood completely. Do not light burners with the hood closed.
2. Do not lean over the grill.
3. Remove the manual lighting extension (see following illustration) and attach a match to the split ring.

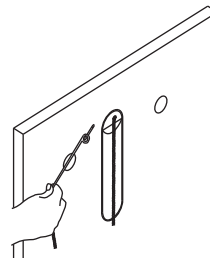

4. Strike the match to light it.
5. Guide the lit match under the grill grate.

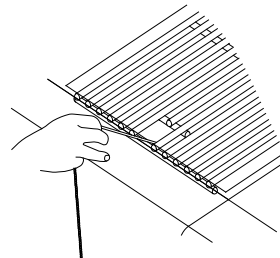

6. Push in and turn the burner knob to IGNITE HIGH for the burner closest to the lit match. The burner will light immediately. When burner is lit, turn knob to desired setting.

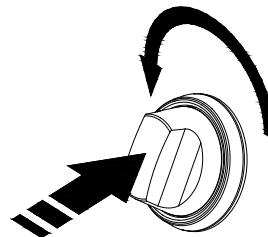

7. Repeat steps 2 through 6 for each main burner.
8. Remove match and replace manual lighting extension on the right side panel.

**IMPORTANT:**

If burner does not light immediately, turn the burner knob to OFF and wait 5 minutes before relighting.

If any burners do not light after attempting to light them manually, contact the Customer Service Center. See the “Assistance” section.

---

## Hood Lights

The grill must be plugged in for the hood lights to work. See “Plug in Grill” in the “Freestanding Outdoor Grill Installation” section.

**To Use:**

Press the LIGHTS button on the control panel to turn the hood lights on and off.

## Using Your Searing Side Burner

Infrared grilling produces intense heat that quickly sears the meat. Searing locks in flavor and juices while allowing the outer surface to absorb smoke and food aroma that is produced as grease and drippings are vaporized by the burner. The result is a crisp, flavorful outside with a tender, juicy inside.

- Preheat the infrared sear burner for 5 minutes.
- Ensure that meats are fully thawed and that all excess fat is trimmed away prior to grilling.
- Leave the burner set to On when placing food on the grill to sear.
- Use the sear burner to sear meat 1 to 2 minutes on each side, then move the meat to the main grill cooking surface to finish grilling to the desired doneness.

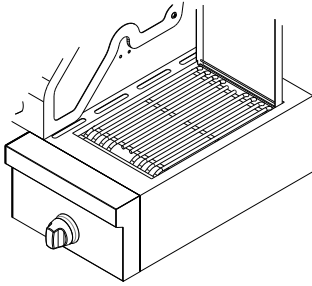

**IMPORTANT:** It is recommended that the sear side burner lid be open when the burner is in use to eliminate the possibility of increased lid and handle temperatures.

- To close the searing side burner lid, first lift up the lid to release the lock then lower it to the closed position.

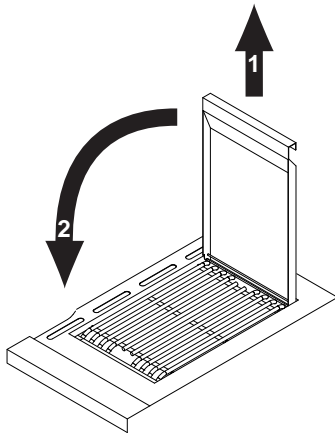

### Lighting the Searing Side Burner

1. Open the searing side burner cover. Do not light burners with the cover on.
2. Do not lean over the grill.
3. Push in and turn the control knob to IGNITE ON and hold in. You will hear the “snapping” sound of the spark. When burner is lit, release the knob. Turn knob to desired setting.

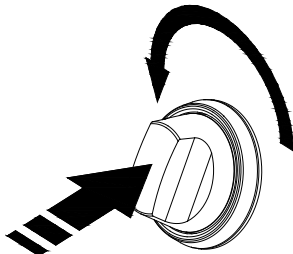

**IMPORTANT:** If burner does not light immediately, turn the burner knob to OFF and wait 5 minutes before relighting.

### Manually Lighting the Searing Side Burner

1. Open the searing side burner cover. Do not light burners with the cover on.
2. Do not lean over the grill.
3. Remove the manual lighting extension (see the following illustration) and attach a match to the split ring.

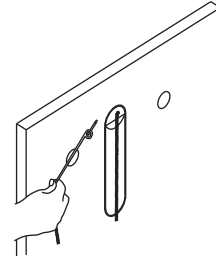

4. Strike the match to light it.
5. Hold the lit match close to the searing side burner.

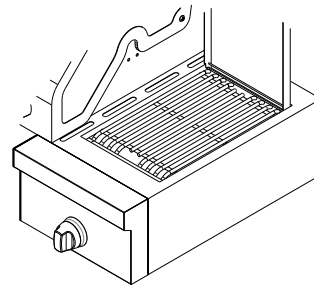

6. Push in and turn the burner knob to IGNITE ON for the burner closest to the lit match. The burner will light immediately. When burner is lit, turn knob to desired setting.

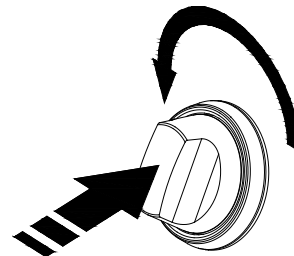

7. Repeat steps 3 through 6 for each burner.
8. Remove match and replace manual lighting extension on the right side panel.

**IMPORTANT:**

If burner does not light immediately, turn the burner knob to OFF and wait 5 minutes before relighting.

If any burners do not light after attempting to light them manually, contact the Customer Service Center. See the “Assistance” section.

## Using Your Rotisserie Burner

A Rotisserie kit can be purchased as an accessory for the grill. See "Accessories" in the "Assistance" section.

To avoid damage to the warming rack, remove from grill when using the rotisserie burner.

**IMPORTANT:** Do not use the main burners when the rotisserie burner is in use.

### Lighting the Rotisserie Burner

1. Open the hood completely. Do not light burners with the hood closed.
2. Do not lean over the grill.
3. Push in and turn the control knob to IGNITE ON. You will hear the "snapping" sound of the spark.



4. When the rotisserie burner lights, continue to hold the knob in for another 10 seconds, then release the knob and burner will stay lit. You will hear the "snapping" sound of the spark until the knob is released.

**IMPORTANT:** If the rotisserie burner does not light immediately, turn the burner knob to OFF and wait 5 minutes before relighting.

### Manually Lighting the Rotisserie Burner

1. Open the hood completely. Do not light burners with the hood closed.
2. Do not lean over the grill.
3. Remove the manual lighting extension (see following illustration) and attach a match to the split ring.

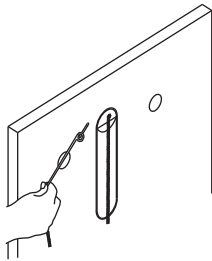

4. Strike the match to light it.
5. Gently hold the lit match close to the rotisserie burner.

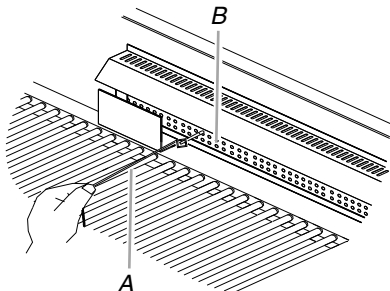

A. Lighting extension  
B. Rotisserie burner

6. Push in and turn the control knob to IGNITE ON. Hold this knob in for 10 seconds after the burner is lit. You will hear the "snapping" sound of the spark until after the knob is released.



**IMPORTANT:** If the rotisserie burner does not light immediately, turn the rotisserie burner control knob to OFF and wait 5 minutes before relighting.

7. Remove the match and replace the manual lighting extension inside the cabinet door.

## Rotisserie Cooking Tips

### ⚠ WARNING

#### Food Poisoning Hazard

**Do not let food sit for more than one hour before or after cooking.**

**Doing so can result in food poisoning or sickness.**

Rotisserie cooking rotates food in front of the rotisserie burner, creating an intense heat for searing the outside and sealing in natural juices.

The rotisserie burner reaches cooking temperatures in about 1 minute. It is not necessary to preheat when using the rotisserie.

- Select tender meat and poultry.
- Allow at least 1" (2.5 cm) space between rotisserie burner and the food.
- To make cleanup easier, place a pan under the food to catch drippings.
- Add barbecue sauce or glaze only during the last 10 minutes of cooking to keep sauce from burning.

### Trussing Poultry for the Rotisserie

1. Load the spit rod by sliding one of the forks on the rod, with the prongs facing inward. Tighten the screw to keep it from slipping.
2. Push the rod through the center of the bird.
3. Cut 24" (61.0 cm) of butcher's string and center it under the bird, breast side up.
4. Wrap each end of the string around the wings; catch each wing tip. Bring the string tightly together at the top of the breast and knot. It is not necessary to cut off the extra string.
5. Cut another 20" (50.8 cm) of string and lay it under the back of the bird. Wrap it around the tail then around the spit rod, cinching tightly.
6. Cross the legs on top of spit rod; tie string around the crossed legs.
7. Connect the twine holding the legs, to the string holding the wings, and knot. Cut off any bits of hanging string.
8. Slide on the second fork, pushing the tines into the drumsticks.
9. Center the food and forks on the rod and tighten the thumb-screws. The bird should be firmly in place on the rotisserie spit rod.

## ROTISSERIE

### CHART

Use a portable meat thermometer to check internal doneness of the food.

Turn off rotisserie burner when meat thermometer reads 5°F/3°C lower than desired internal temperature. Continue rotating, hood closed, for 10 minutes before carving.

Timing is affected by weather conditions such as wind and outside temperature.

Food	Weight	Internal Doneness or Temperature (°F/°C)	Approximate Grilling Time (min/lb)
<b>Beef</b>			
Roasts	4-6 lbs	Medium-rare	15-20
Rib Eye	(1.5-2.2 kg)	(145°F/ 63°C)	
Sirloin Tip		Medium	20-25
Rib, boneless		(160°F/71°C)	
<b>Poultry</b>			
Chicken	3-6 lbs (1.1-2.2 kg)	Breast	25-30
		(170°F/ 77°C)	
		Thigh	25-30
		(180°F/82°C)	
Turkey, whole	7-10 lbs (2.6-3.7 kg)	Breast	11-20
		(170°F/77°C)	
		Thigh	11-20
		(180°F/82°C)	
<b>Lamb</b>			
Boneless leg	4-7 lbs (1.5-2.6 kg)	Medium	20-25
		(160°F/71°C)	
<b>Pork</b>			
Loin roast, boneless	4-6 lbs (1.5-2.2 kg)	Medium	20-23
		(160°F/71°C)	

## TIPS FOR OUTDOOR GRILLING

### WARNING

#### Food Poisoning Hazard

Do not let food sit for more than one hour before or after cooking.

Doing so can result in food poisoning or sickness.

### Before Grilling

- Thaw food items before grilling.
- Preheat grill on high (use all grill burners) 10 minutes. The hood must be closed during preheating. There is no need to use the back rotisserie burner for preheating. Preheating provides the high heat needed to brown and seal the juices.
- Shorten the preheat time when grilling high-fat cuts of meat or poultry, such as chicken thighs. This will help reduce flare-ups.
- Lightly oil the grill grates or the food when cooking low-fat cuts of meat, fish or poultry, such as lean hamburger patties, shrimp or skinless chicken breasts.
- Using too much oil can cause gray ash to deposit on food.
- Trim excess fat from meats prior to cooking to reduce flare-ups.
- Make vertical cuts at 2" (5 cm) intervals around the fat edge of meat to avoid curling.
- Add seasoning or salt only after the cooking is finished.

### During Grilling

- Turn foods only once. Juices are lost when meat is turned several times.
- Turn meat just when juices begin to appear on the surface.
- Avoid puncturing or cutting the meats to test doneness. This allows juices to escape.
- It may be necessary to lower the heat setting for foods that cook a long time or are marinated or basted in a sugary sauce.
- If using a high flame, add barbecue sauce only during the last 10 minutes of cooking to avoid burning the sauce.
- The degree of doneness is influenced by the type of meat, cut of meat (size, shape and thickness), heat setting selected, and length of time on the grill.
- Cooking time will be longer with an open grill cover.

## Cooking Methods

### Direct Heat

Cooking by direct heat means the food is placed on grill grates directly above lighted burners. Hood position can be up or down. If hood is in the up position, total cooking times may be longer.

Direct heat sears the food. Searing is a process that seals natural juices in food by cooking with intense heat for a short period of time. While juices stay inside, the outside is browned with a flavorful grilled coating.

### Indirect Heat

For best results, do not select the indirect heat cooking method when it is windy.

Cooking by indirect heat means the food is placed on the grill grate above an unheated burner, allowing heat from lighted burner(s) on either side to cook the food.

If possible, turn on 2 burners. Cook with the hood down. This will shorten the cooking time.

## Grilling Chart

- Knobs have High, Medium and Low settings for flame adjustment.
- Heat settings indicated are approximate.
- Grilling times are affected by weather conditions.
- When 2 temperatures are listed, for example: Medium to Medium-Low, start with the first and adjust based on cooking progress.
- Cooking times may vary from chart times depending on the type of fuel, Natural or LP gas.

FOOD	COOKING METHOD/ BURNER SETTING	INTERNAL TEMP.	TIME (total minutes)	SPECIAL INSTRUCTIONS
<b>Beef</b>				
Hamburgers ½" (1.3 cm) to ¾" (1.9 cm) thick	DIRECT Medium	Medium (160°F/71°C)	10-15	Grill, turning once.
Roasts Rib Eye, Sirloin	INDIRECT Medium/OFF/Medium	Med-Rare (145°F/63°C) to Medium (160°F/71°C)	32-40 per lb (15-18 per kg)	Tent with foil first 45-60 minutes of cooking time.
Steaks, 1" (2.5 cm) Porterhouse, Rib, T-bone, Top Loin, Sirloin	DIRECT Medium	Med-Rare (145°F/63°C) to Medium (160°F/71°C)	11-16	Rotate steaks ¼ turn to create criss-cross grill marks.
Steaks, 1½" (3.8 cm) Porterhouse, Rib, T-bone, Top Loin, Sirloin	DIRECT Medium	Med-Rare (145°F/63°C) to Medium (160°F/71°C)	18-25	
Top Round or Shoulder/ Chuck (London Broil) 1½" (3.8 cm) thick	DIRECT Medium	Med-Rare (145°F/63°C) to Medium (160°F/71°C)	22-29	
Flank, ½" (1.3 cm) thick	DIRECT Medium	Med-Rare (145°F/63°C)	11-16	
<b>Pork</b>				
Chops, 1" (2.5 cm) 1½" (3.8 cm) thick	DIRECT Medium to Med-Low	Medium (160°F/71°C)	12-22 30-40	
Ribs 2½-4 lbs (0.9-1.5 kg)	INDIRECT Med/OFF/Med	Medium (160°F/71°C)	40-60	Grill, turning occasionally. During last few minutes, brush with barbecue sauce if desired. When done, wrap in foil.
Roast, boneless tenderloin, 1 lb (0.37 kg)	DIRECT Medium	Medium (160°F/71°C)	18-22	Turn during cooking to brown on all sides.
Ham half, 8-10 lbs (3-3.7 kg)	INDIRECT Med/OFF/Med	Reheat (140°F/60°C)	2-2½ hours	Wrap entire ham in foil and put on grill without pan or drip pan.
Ham steak precooked, ½" (1.3 cm) thick	DIRECT Preheat Medium Grill Medium	Reheat (145°F/63°C)	7-10	
Hot Dogs	DIRECT Medium	Reheat (145°F/63°C)	5-10	Slit skin if desired.
<b>Chicken</b>				
Breast, boneless	DIRECT Medium	170°F/77°C	15-22	For even cooking, pound breast to ¾" (2.0 cm) thick.
Pieces, 2-3 lbs (0.75-1.1 kg)	DIRECT Med-Low to Medium	Breast 170°F/77°C Thigh 180°F/82°C		Start bone side down.

<b>FOOD</b>	<b>COOKING METHOD/ BURNER SETTING</b>	<b>INTERNAL TEMP.</b>	<b>TIME (total minutes)</b>	<b>SPECIAL INSTRUCTIONS</b>
<b>Lamb</b>				
Chops and Steaks, Loin, Rib, Sirloin 1" (2.5 cm) thick	DIRECT Medium	Med-rare (145°F/63°C) to Medium (160°F/71°C)	10-20	
1½" (3.8 cm) thick	DIRECT Medium	Med-rare (145°F/63°C) to Medium (160°F/71°C)	16-20	
<b>Fish and Seafood</b>				
Fillets, Steaks, Chunks Halibut, Salmon, Swordfish, 8 oz (0.25 kg)	DIRECT Medium		4-6 per ½" (1.3 cm) thickness of fish	Grill, turning once. Brush grill with oil to keep fish from sticking. Remove when inside is opaque and flaky with skin easily removed.
Whole, Catfish, Rainbow Trout, 8-11 oz (0.25-0.34 kg)	DIRECT High		5-7 per side	
Shellfish, Scallops, Shrimp	DIRECT Medium		4-8	
<b>Turkey</b>				
Whole breast (bone-in)	INDIRECT High/OFF/High	170°F/77°C	14-18 per lb (7-8 per kg)	Tent with foil until last 30 minutes of cooking time.
Half breast (bone-in)	INDIRECT Medium/OFF/Medium	170°F/77°C	25-30 per lb (11-14 per kg)	Start skin side down.
Whole, 7-12 lbs (2.6-5.4 kg)	INDIRECT High/OFF/High	Breast 170°F/77°C Thigh 180°F/82°C	11-16 per lb (5-7 per kg)	Less than 11 lbs (5.0 kg)
<b>Fresh Vegetables</b>				
Corn on the cob	DIRECT Medium		20-25	Soak in cold water 20 minutes. Do not husk. Shake off excess water.
Eggplant	DIRECT Medium		7-10	Wash and cut into ½" (1.3 cm) slices or lengthwise. Brush with olive oil.
Onion, ½" (1.3 cm) thick	DIRECT Medium		8-20	Grill, turning once. Brush with olive oil. Put a skewer through several slices to hold together.
Potatoes, Sweet, whole	DIRECT Medium		40-70	Individually wrap in heavy-duty foil. Grill, rotating occasionally.
Baking, whole	DIRECT High		45-90	
Peppers, Roasted	DIRECT High		15-22	Wash and place on grill whole. Char skin all around. Cool in a paper bag or plastic wrap to loosen blackened skin. Peel and remove seeds.
Squash, Summer, Zucchini	DIRECT Medium		7-10	Wash and cut into ½" (1.3 cm) slices or lengthwise. Brush with olive oil.
Garlic Roasted	DIRECT Medium		20-25	Cut off top, drizzle with olive oil and wrap in double layer of foil.

# OUTDOOR GRILL CARE

## Replacing the Igniter Battery

If igniters stop sparking, the battery should be replaced.

1. The igniter button cap is located on the outside of the grill's right side panel.
2. Unscrew igniter button cap counterclockwise to remove.

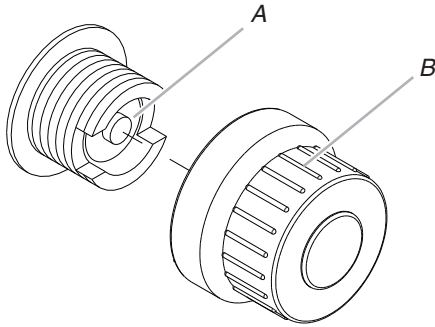

A. "AA" size battery  
B. Igniter cap

3. Remove battery from the battery compartment.
4. Replace with a new alkaline "AA" size battery. Install battery with negative end in first.
5. Screw igniter button cap clockwise into place.

## Changing the Light Bulb

1. Unplug grill or disconnect power.
2. Make sure the light power switch on the control panel is in the OFF position.
3. Use a Phillips screwdriver to remove the four screws securing the light cover to the grill hood.

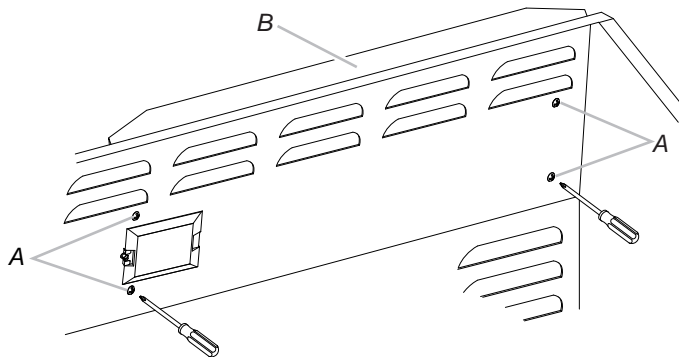

A. Remove these screws.  
B. Grill hood

**NOTE:** When removing final screw from the light cover, make sure to hold the cover in place, ensuring it doesn't fall and shatter.

4. Loosen the screw securing the light assembly to the grill hood and pull out the light with glass light cover.

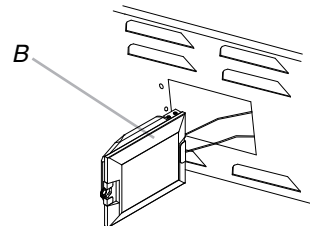
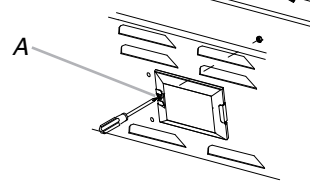

A. Screw  
B. Light assembly

5. To remove glass light cover, remove screw and gently pry downward with a small flat-blade screwdriver at the left edge of the cover near the screw and pull away from the retainer. Pull out the clamp from the end of the light assembly.

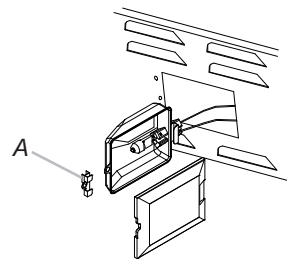
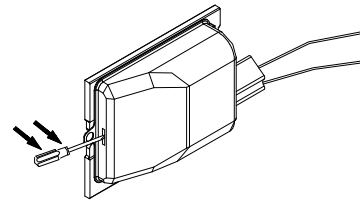

A. Clamp

6. Use a flat-blade screwdriver to remove the screw locking the bulb into place.

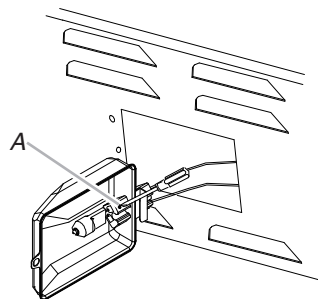

A. Screw

7. Remove bulb from socket.



- Replace bulb with a new 12-volt, 10-watt maximum, halogen bulb, using a tissue or wearing cotton gloves to handle the bulb. To avoid damaging the bulb, do not touch the bulb with bare fingers.

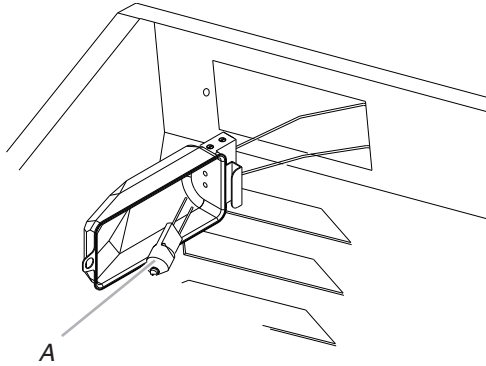

- Tighten the two screws to lock the bulb into place.
- Replace glass light cover onto light assembly. Secure light assembly into the grill hood with the screws removed in Step 4. Secure light cover onto grill hood with four screws removed in Step 3.
- Plug in grill or reconnect power.

## General Cleaning

**IMPORTANT:** Before cleaning, make sure all controls are off and the grill is cool. Always follow label instructions on cleaning products.

For routine cleaning, wash with soap and water using a soft cloth or sponge. Rinse with clean water and dry at once with a soft, lint-free cloth to avoid spots and streaks.

Do not use steel wool to clean the grill, as it will scratch the surface.

To avoid weather damage to finish, use vinyl grill cover.

## STAINLESS STEEL

**IMPORTANT:** To avoid damage to stainless steel surfaces, do not use soap-filled scouring pads, abrasive cleaners, cooktop polishing creme, steel wool, gritty washcloths or paper towels.

Cleaners should not contain chlorine. Damage may occur.

Food spills should be cleaned as soon as entire grill is cool. Spills may cause permanent discoloration.

### Cleaning Method:

- Rub in direction of grain to avoid scratching or damaging the surface.
- Stainless steel cleaner.
- Liquid detergent or all-purpose cleaner.
- Rinse with clean water and dry with soft, lint-free cloth.
- Vinegar to remove hard water spots.
- Glass cleaner to remove fingerprints.

## GRILL GRATES

**IMPORTANT:** To avoid damage to grill grates, do not use a steel or fiber scraper. Immediately after you are finished cooking, loosen food soil with a brass bristle brush. Turn all burners to HIGH for 10-15 minutes with the hood closed to burn off food soil. Turn off all burners, raise the hood and let grates cool. Use the brass bristle brush to remove ash from the grill grates.

When completely cool, grill racks can be removed for thorough cleaning. Clean them with a mild detergent and warm water.

For baked-on soil, prepare a solution of 1 cup (250 mL) ammonia to 1 gal. (3.75 L) water. Soak grates for 20 minutes, then rinse with water and dry completely.

## WARMING SHELF

### Cleaning Method:

- Liquid detergent or an all-purpose cleaner.
- Rinse with clean water and dry with soft, lint-free cloth.
- For tough spots or baked-on grease, use a commercial degreaser designed for stainless steel.

**IMPORTANT:** Make sure gas supply is off and all control knobs are in the Off position.

## EXTERIOR

The quality of this material resists most stains and pitting, providing that the surface is kept clean, polished and covered.

- Apply stainless steel polish to all non-cooking areas before first use. Reapply after each cleaning to avoid permanent damage to surface.
- Cleaning should always be followed by rinsing with clean warm water. Wipe the surface completely dry with a soft cloth.
- For tough spots or baked-on grease, use a commercial degreaser designed for stainless steel.

## INTERIOR

Discoloration of stainless steel on these parts is to be expected, due to intense heat from the burners. Always rub in the direction of the grain. Cleaning should always be followed by rinsing with clean, warm water.

### Cleaning Method:

- Liquid detergent or all-purpose cleaner.
- Rinse with clean water and dry completely with a soft, lint-free cloth.
- A heavy-duty scrub sponge can be used with mild cleaning products.
- For small, difficult-to-clean areas, use a commercial degreaser designed for stainless steel.

---

## BURNERS

---

### Cleaning Method:

- Clean the exterior of the burner with a wire brush.
- Clear any clogged burner ports with a straightened paper clip.
- Do not use a toothpick as it may break off and clog the port.
- Check and clean burner/venturi tubes.
  1. Remove grill grates and flame tamers.
  2. Remove the 1 screw and cotter clip that hold the burner in the place. Remove gas burner from the grill.

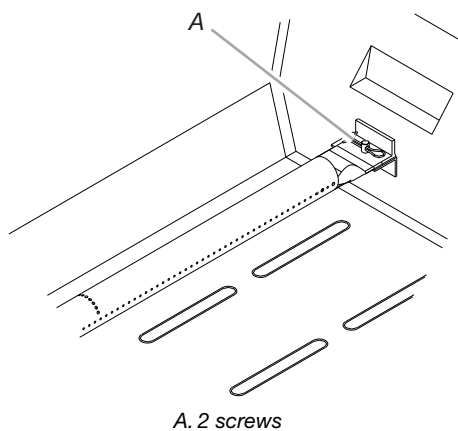

3. Use a flashlight to inspect into the burner through the burner inlet to ensure there is no blockage. If any obstruction is seen, use a metal coat hanger that has been straightened to clear them.
4. After inspecting the inside of burner for blockage, reassemble burner by sliding the middle tube of the gas burner over the gas orifice.

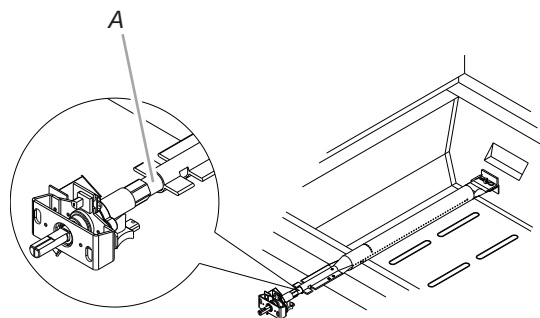

5. Reattach gas burner using 2 screws.

---

## SEARING SIDE BURNER

---

### Cleaning Method:

- Clean the exterior of the sear burner with a wire brush.

---

## ROTISSIERE BURNER

---

### Cleaning Method:

1. Light the rotisserie burner. See the “Using Your Rotisserie Burner” section.
2. Close the grill hood.
3. Leave the burner on high for approximately 30 minutes.
4. Turn knob to OFF and let cool completely.
5. Brush off ash particles from the rotisserie burner.

---

## DRIP TRAY

---

**IMPORTANT:** The drip tray should only be removed when grill is completely cool.

The full-width drip tray collects grease and food particles that fall through the grill. Clean often to avoid grease buildup.

### Cleaning Method:

- Remove tray and set on a flat surface.
- Wipe excess grease with paper towels.
- Mild detergent and warm water. Rinse and dry thoroughly.
- Replace tray.

---

## KNOBS AND FLANGE AREA AROUND KNOBS

---

**IMPORTANT:** To avoid damage to knobs or flange area around knobs, do not use steel wool, abrasive cleaners, or oven cleaner. Do not soak knobs.

### Cleaning Method:

- Mild detergent, a soft cloth and warm water.
- Rinse and dry.

---

## CONTROL PANEL GRAPHICS

---

**IMPORTANT:** To avoid damage to control panel graphics, do not use steel wool, abrasive cleaners or oven cleaner.

Do not spray cleaner directly onto panel.

### Cleaning Method:

- Clean around the burner labels gently; scrubbing may remove printing.
- Mild detergent, soft cloth and warm water.
- Rinse and dry.

---

# TROUBLESHOOTING

---

## Grill will not light

---

- **Is the 20 lb LP gas fuel tank valve turned off?**  
Turn the 20 lb LP gas fuel tank on.
- **Is the grill properly connected to the gas supply?**  
Contact a trained repair specialist or see Installation Instructions.
- **Is there gas in the 20 lb LP gas fuel tank?**  
Check the gas level.
- **Is the igniter working?**  
Check that the igniter battery is properly installed or check to see if the battery needs to be replaced. See the “Replacing the Igniter Battery” section.  
  
Check to see if the grill will match-light. See “Manually Lighting the Grill and Searing Side Burner” in the “Outdoor Grill Use” section.  
  
Check for loose wire connections to the igniter or electrodes.  
  
Check to see if debris is blocking the electrodes.  
  
If a spark occurs anywhere but the igniter tip, replace the igniter.

---

## Burner flame will not stay lit

---

- **Is the gas supply fully turned on?**  
Check that the 20 lb LP gas fuel tank valve is fully open.
- **Is the gas supply in the 20 lb LP fuel gas tank low?**  
Check the gas level.
- **Is the burner properly installed and in good condition?**  
Check that the burner is installed properly. Check for defects in the burner.

---

## Flame is noisy, low or erratic

---

- **Is the gas supply fully turned on?**  
Check that the 20 lb LP gas fuel tank valve is fully open.
- **Is the gas supply in the 20 lb LP fuel gas tank low?**  
Check the gas level.
- **Does only one burner appear low?**  
Check and clean the burner ports if clogged or dirty. See “General Cleaning” section.
- **Is the gas supply hose bent or kinked?**  
Straighten the gas supply hose.
- **Is the flame noisy or lifting away from the burner?**  
Burner may be getting too much air. Check the air shutter adjustment, see “Check and Adjust the Burners” section.
- **Is the burner flame mostly yellow or orange?**  
Grill may be in an area that is too windy, or not receiving enough air. Check the burner air inlets for obstructions. Check the air shutter adjustment, see “Check and Adjust the Burners” section.

---

## Excessive flare-ups

---

- **Is there excessive fat in the food being grilled?**  
Keep flame on low or turn one burner off.  
  
Keep the hood up when grilling to avoid excessive flare-ups.  
  
Move food to the warming rack until flames subside.  
  
To avoid damage to the grill, do not spray water on gas flames.

---

## Low heat

---

### LP Gas:

For outdoor grills using a 20lb LP gas fuel tank, slowly open the tank valve.

**NOTE:** If flow limiting device activates, your grill may not light. If your grill does light, the flames will be low and will not heat properly.

1. Turn tank valve and all control knobs off and wait 30 seconds.
2. After shutting off the tank, very slowly open the tank valve and wait 5 seconds before lighting.
3. Light the burners one at a time. See “Lighting the Grill and Searing Side Burner” section.

### Natural Gas:

Gas pressure is affected by size and length of the gas line from the house to the grill. Contact a qualified gas technician to provide the Natural gas supply to the selected grill location in accordance with the National Fuel Gas Code ANSI Z223.1/NFPA54 - latest edition, and local codes.

---

# ASSISTANCE

Before calling for assistance, please check “Troubleshooting.” If you still need help, follow the instructions below.

When calling, please know the purchase date and the complete model and serial number of your appliance. This information will help us to better respond to your request.

### If you need replacement parts

If you have questions or need to order replacement parts, contact Customer Service Center at **1-877-373-2301**.

Please direct all correspondence to:

Nexgrill Industries, Inc.  
5270 Edison Avenue  
Chino, CA 91710

Please include a daytime phone number in your correspondence.

---

## Accessories

### Natural Gas Conversion Kit

Order Part Number 710-0003

### Rotisserie Kit

Order Part Number 790-0007

---

# LIMITED WARRANTY

Nexgrill warrants to the original consumer-purchaser only that this product (*Model #720/730-0745A*) shall be free from defects in workmanship and materials after correct assembly and under normal and reasonable home use for the periods indicated below beginning on the date of purchase. The manufacturer reserves the right to require photographic evidence of damage, or that defective parts be returned, postage and or freight pre-paid by the consumer, for review and examination.

**Stainless steel tube burners:** 5 year LIMITED warranty against perforation; **Other burners (Searing & rotisserie):** 1 year.

**Grids and grates:** 3 Year LIMITED warranty; does not cover dropping, chipping, scratching, or surface damage.

**Stainless steel parts:** 3 Year LIMITED warranty against perforation; does not cover cosmetic issues like surface corrosion, scratches and rust.

**All other parts:** 1 Year LIMITED warranty (Includes, but not limited to, valves, frame, housing, cart, control panel, igniter, regulator, hoses); does not cover chipping, scratching, cracking surface corrosion, scratches or rust.

Upon consumer supplying proof of purchase as provided herein, Manufacturer will repair or replace the parts which are proven defective during the applicable warranty period. Parts required to complete such repair or replacement shall be free of charge to you except for shipping costs, as long as the purchaser is within the warranty period from the original date of purchase. The original consumer-purchaser will be responsible for all shipping charges of parts replaced under the terms of this limited warranty. This limited warranty is applicable in the United States only, is only available to the original owner of the product and is not transferable. Manufacturer requires reasonable proof of your date of purchase. Therefore, you should retain your sales receipt and/or invoice. If the unit was received as a gift, please ask the gift-giver to send in the receipt on your behalf, to the below address. Defective or missing parts subject to this limited warranty will not be replaced without registration or proof of purchase. This limited warranty applies to the functionality of the product ONLY and does not cover cosmetic issues such as scratches, dents, corrosions or discoloring by heat, abrasive and chemical cleaners or any tools used in the assembly or installation of the appliance, surface rust, or the discoloration of stainless steel surfaces. Surface rust, corrosion, or powder paint chipping on metal parts that does not affect the structural integrity of the product is not considered a defect in workmanship or material and is not covered by this warranty. This limited warranty will not reimburse you for the cost of any inconvenience, food, personal injury or property damage. If an original replacement part is not available, a comparable replacement part will be sent. You will be responsible for all shipping charges of parts replaced under the terms of this limited warranty.

## ITEMS MANUFACTURER WILL NOT PAY FOR:

- Service calls to your home.
- Repairs when your product is used for other than normal, single-family household or residential use.
- Damage resulting from accident, alteration, misuse, lack of maintenance/cleaning, abuse, fire, flood, acts of God, improper installation, and installation not in accordance with electrical or plumbing codes or use of products not approved by the manufacturer.
- Any food loss due to product failures.
- Replacement parts or repair labor costs for units operated outside the United States or Canada.
- Pickup and delivery of your product.
- Postage fees or photo processing fees for photos sent in as documentation.
- Repairs to parts or systems resulting from unauthorized modifications made to the product.
- The removal and/or reinstallation of your product.
- Shipping cost, standard or expedited, for warranty/non warranty and replacement parts.

## DISCLAIMER OF IMPLIED WARRANTIES; LIMITATION OF REMEDIES

*Repair or replacement of defective parts is your exclusive remedy* under the terms of this limited warranty. Manufacturer will not be responsible for any consequential or incidental damages arising from the breach of either this limited warranty or any applicable implied warranty, or for failure or damage resulting from acts of God, improper care and maintenance, grease fire, accident, alteration, replacement of parts by anyone other than Manufacturer, misuse, transportation, commercial use, abuse, hostile environments (inclement weather, acts of nature, animal tampering), improper installation or installation not in accordance with local codes or printed manufacturer instructions.

THIS LIMITED WARRANTY IS THE SOLE EXPRESS WARRANTY GIVEN BY THE MANUFACTURER. NO PRODUCT PERFORMANCE SPECIFICATION OR DESCRIPTION WHEREVER APPEARING IS WARRANTED BY MANUFACTURER EXCEPT TO THE EXTENT SET FORTH IN THIS LIMITED WARRANTY. ANY IMPLIED WARRANTY PROTECTION ARISING UNDER THE LAWS OF ANY STATE, INCLUDING IMPLIED WARRANTY OF MERCHANTABILITY OR FITNESS FOR A PARTICULAR PURPOSE OR USE, IS HEREBY LIMITED IN DURATION TO THE DURATION OF THIS LIMITED WARRANTY.

Neither dealers nor the retail establishment selling this product has any authority to make any additional warranties or to promise remedies in addition to or inconsistent with those stated above. Manufacturer's maximum liability, in any event, shall not exceed the documented purchase price of the product paid by the original consumer. This warranty only applies to units purchased from an authorized retailer and or re-seller.

NOTE: Some states do not allow an exclusion or limitation of incidental or consequential damages, so some of the above limitations or exclusions may not apply to you; this limited warranty gives you specific legal rights as set for herein. You may also have other rights which vary from state to state.

If you wish to obtain performance of any obligation under this limited warranty, you should write to:

**Nexgrill Customer Relations**  
**5270 Edison Avenue,**  
**Chino, CA 91710**

*All consumer returns, parts orders, general questions, and troubleshooting assistance can be acquired by calling 1-877-373-2301.*

---

## Notes